

NINGBO ZHAFIR PLASTICS MACHINERY MANUFACTURING CO., LTD.

No. 98 Guanhai Road, Chunxiao, Beilun, Ningbo, China 315800

Tel. +86-574-86182986

Fax. +86-574-86182977

E-Mail: contact@mail.zhafir.cn

www.zhafir.cn



ZF 20210408-IV

ZERES III

SPECIFICATION | INTERNATIONAL

400 – 3,600 kN



TECHNICAL DATA ZE400 III

		ZE400 III					
CLAMPING UNIT	Clamping force	kN	400				
	Mold opening stroke	mm	235				
	Mold height min.	mm	150				
	Mold height max.	mm	320				
	Max. daylight	mm	555				
	Dist. between tie bars (H×V)	mm	320×320				
	Min. mold dimension	mm	205×205				
	Ejector stroke	mm	60				
	Ejector force	kN	17.2				
	Size of mold platen (H×V)	mm	460×460				
INJECTION UNIT			A	B	A	B	C
	Screw diameter	mm	16	19	19	22	26
	Screw L/D ratio	L/D	21	20	21	22	18
	Injection volume (theoretical) ¹	cm ³	12	17	21	36	50
	Injection weight (PS) ²	g	10.9	15.4	19.1	32.8	45.5
	Injection pressure ³	MPa	280	260	260	220	157
		bar	2800	2600	2600	2200	1570
	Holding pressure ³	MPa	234	198	208	175	125
		bar	2340	1980	2080	1750	1250
	Screw speed	rpm	400		400		
Plasticizing rate (GPPS) ⁴	g/s	2.5	3.6	3.8	6.0	8.0	
Nozzle contact force	kN	26		26			
Heating power	kW	4.3	4.6	4.4	5.6	5.6	
INJECTION UNIT			50		80		
	Injection speed	mm/s	200		200		
	Injection rate (PS)	g/s	35	49	49	66	92
			50h		80h		
INJECTION UNIT	Injection speed	mm/s	350		350		
	Injection rate (PS)	g/s	61	86	86	116	162
OTHERS	Connection power	kW/A	50:10/16 50h:10/16		80:10/17 80h:12/21		
	Pressure	MPa	17.5		17.5		
	Flow	l/min	24		24		
	Oil tank	l	48		48		
	Hopper capacity	l	15		15		
	Machine dimension	m	3.7×1.3×1.9		3.7×1.3×1.9		
	Machine weight	t	2.7		2.7		

NOTE: ¹ Shot volume is the theoretical value which equals to cross section area of screw cylinder or barrel plunger × screw stroke.

² Shot weight (PS) is the theoretical value of shot volume melt density of PS. It is not a measured value.

³ Injection & holding pressure are theoretical values of machine output, not the actual resin pressure.

⁴ Plasticizing capacity(GPPS):GB standard, with application of GPPS plasticizing capacity of 3-zone screws.

This parameter table is based on machine standard configuration;
We reserve the right to make changes as a result of further technical advances.

MACHINE DIMENSIONS

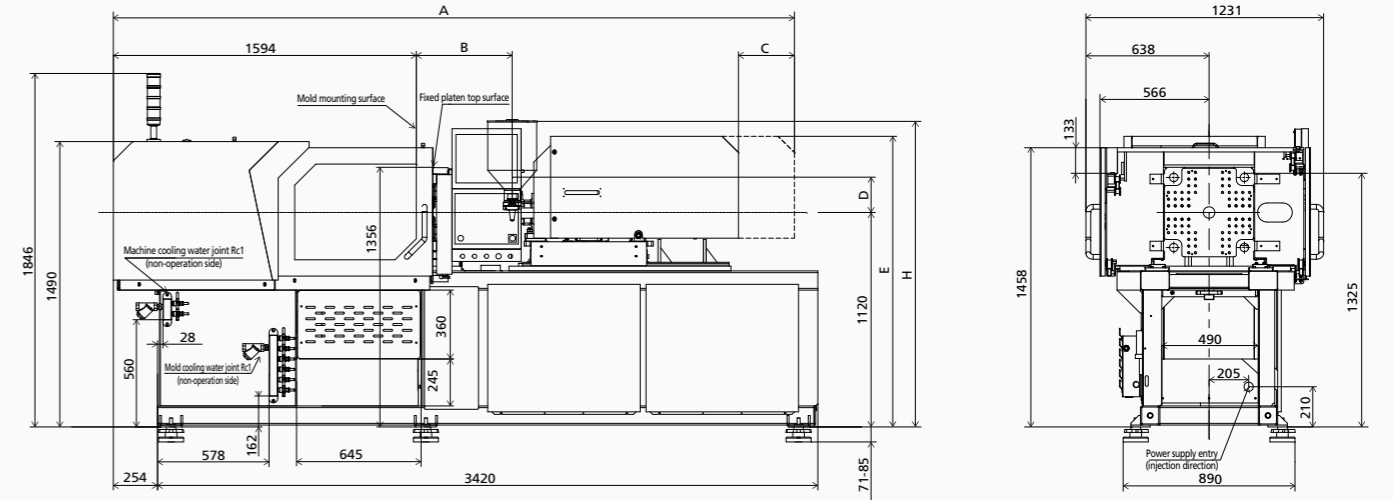

	A	B	C	D	E	F	G	H	I	J	K	L	M	N
50h,50	3507	488	290	199	1518	4×M8 L16	70	1768	110	Ø35	85	59	Ø2	SR10
80h,80	3641	583	290	184	1518	4×M8 L16	70	1753	95	Ø35	85	97	Ø2.2	SR10

PLATEN DIMENSIONS

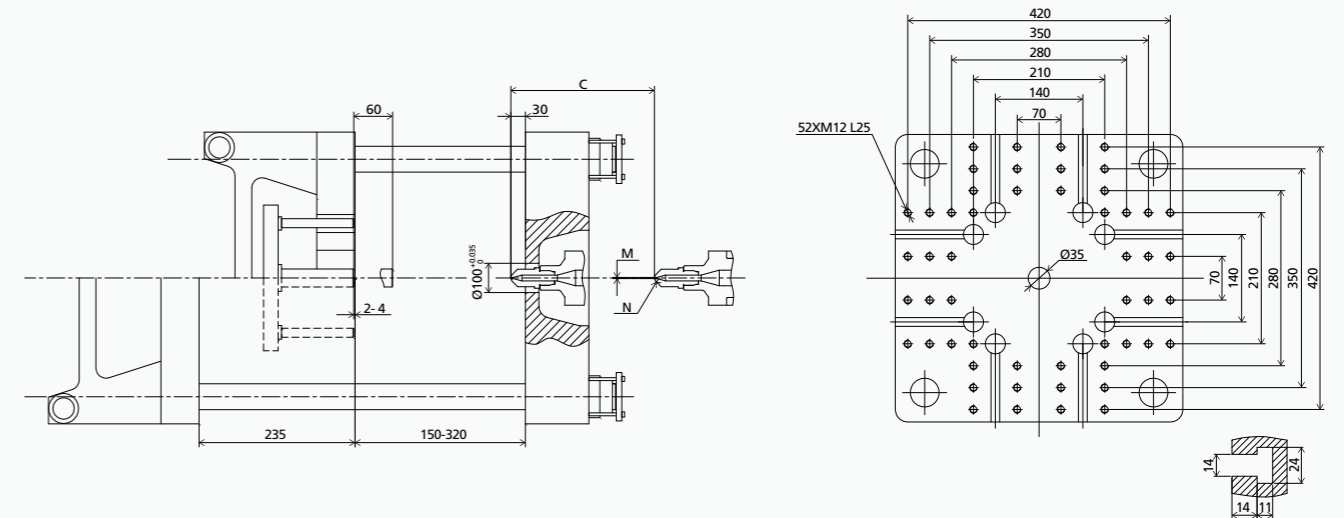

OTHERS DIMENSIONS

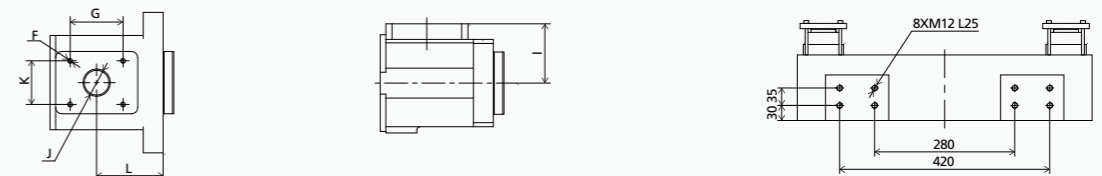

TECHNICAL DATA ZE600 III

		ZE600 III						
CLAMPING UNIT	Clamping force	kN	600					
	Mold opening stroke	mm	270					
	Mold height min.	mm	150					
	Mold height max.	mm	370					
	Max. daylight	mm	640					
	Dist. between tie bars (H×V)	mm	370×370					
	Min. mold dimension	mm	240×240					
	Ejector stroke	mm	80					
	Ejector force	kN	24.5					
	Size of mold platen (H×V)	mm	545×545					
INJECTION UNIT			A	B	C	A	B	C
	Screw diameter	mm	19	22	26	22	26	30
	Screw L/D ratio	L/D	21	22	18	22	22	19
	Injection volume (theoretical) ¹	cm ³	21	36	50	36	58	77
	Injection weight (PS) ²	g	19.1	32.8	45.5	32.8	52	70
	Injection pressure ³	MPa	260	220	157	280	220	165
		bar	2600	2200	1570	2800	2200	1650
	Holding pressure ³	MPa	208	175	125	220	160	120
		bar	2080	1750	1250	2200	1600	1200
	Screw speed	rpm	400		400			
Plasticizing rate (GPPS) ⁴	g/s	3.8	6.0	8.0	6.0	8.8	13	
Nozzle contact force	kN	26		26				
Heating power	kW	4.4	5.6	5.6	6.0	7.8	7.8	
INJECTION UNIT			80			120		
	Injection speed	mm/s	200			200		
	Injection rate (PS)	g/s	49	66	92	66	92	123
			80h			120h		
INJECTION UNIT	Injection speed	mm/s	350			350		
	Injection rate (PS)	g/s	86	116	162	116	162	216
OTHERS	Connection power	kW/A	80:10/17 80h:12/21			120:14/23 120h:16/27		
	Pressure	MPa	17.5			17.5		
	Flow	l/min	30			30		
	Oil tank	l	58			58		
	Hopper capacity	l	15			15		
	Machine dimension	m	4.1×1.3×2.0			4.1×1.3×2.0		
	Machine weight	t	3.2			3.3		

NOTE: ¹ Shot volume is the theoretical value which equals to cross section area of screw cylinder or barrel plunger × screw stroke.

² Shot weight (PS) is the theoretical value of shot volume melt density of PS. It is not a measured value.

³ Injection & holding pressure are theoretical values of machine output, not the actual resin pressure.

⁴ Plasticizing capacity(GPPS):GB standard, with application of GPPS plasticizing capacity of 3-zone screws.

This parameter table is based on machine standard configuration;
We reserve the right to make changes as a result of further technical advances.

MACHINE DIMENSIONS

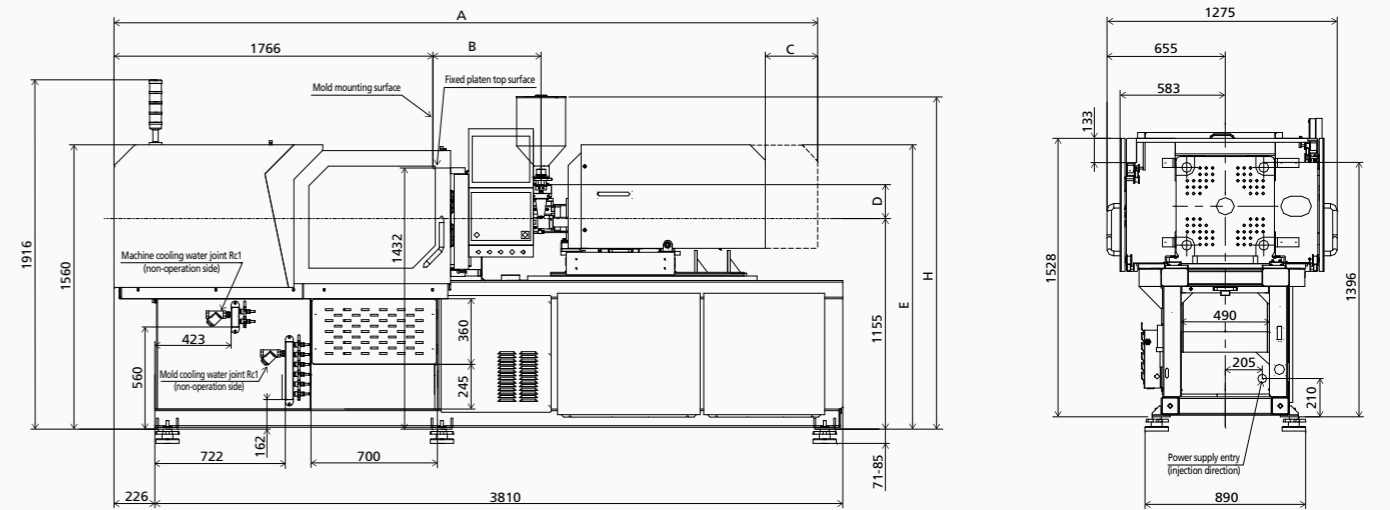

	A	B	C	D	E	F	G	H	I	J	K	L	M	N
80h,80	3812	583	290	184	1553	4×M8 L16	70	1788	95	Ø35	85	97	Ø2.2	SR10
120h,120	3995	697	290	184	1559	4×M8 L16	70	1788	95	Ø40	85	107	Ø2.5	SR10

PLATEN DIMENSIONS

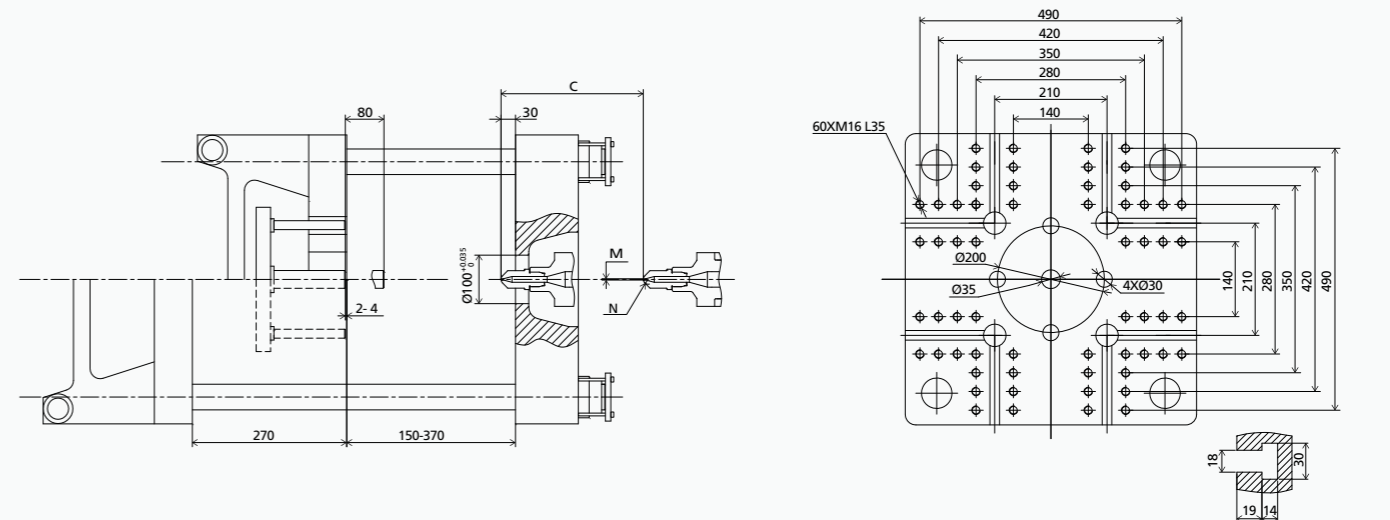

OTHERS DIMENSIONS

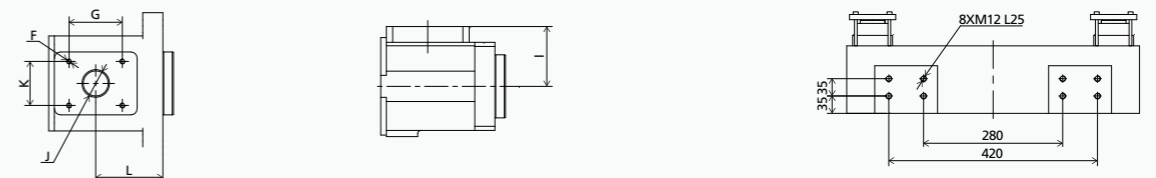

TECHNICAL DATA ZE900 III

		ZE900 III										
CLAMPING UNIT	Clamping force	kN	900									
	Mold opening stroke	mm	320									
	Mold height min.	mm	150									
	Mold height max.	mm	410									
	Max. daylight	mm	730									
	Dist. between tie bars (H×V)	mm	420×420									
	Min. mold dimension	mm	270×270									
	Ejector stroke	mm	80									
	Ejector force	kN	24.5									
	Size of mold platen (H×V)	mm	615×615									
INJECTION UNIT			A	B	C	A	B	C	AA	A	B	C
	Screw diameter	mm	22	26	30	26	28	30	26	28	32	36
	Screw L/D ratio	L/D	22	22	19	22	21	19	21	21	21	18.6
	Injection volume (theoretical) ¹	cm ³	36	58	77	58	67	77	61	70	100	127
	Injection weight (PS) ²	g	32.8	52	70	52	61	70	55	64	91	115
	Injection pressure ³	MPa	280	220	165	260	220	192	280	260	200	160
		bar	2800	2200	1650	2600	2200	1920	2800	2600	2000	1600
	Holding pressure ³	MPa	220	160	120	160	138	120	224	206	160	126
		bar	2200	1600	1200	1600	1380	1200	2240	2060	1600	1260
	Screw speed	rpm	400			400			400			
Plasticizing rate (GPPS) ⁴	g/s	6.0	8.8	13	8.8	11	13	8.5	11	16	19.4	
Nozzle contact force	kN	26			26			26				
Heating power	kW	6.0	7.8	7.8	7.4	7.4	7.4	6.9	7.8	9.2	9.2	
OTHERS	INJECTION UNIT		120			160			210			
	Injection speed	mm/s	200			200			200			
	Injection rate (PS)	g/s	66	92	123	92	107	123	92	107	140	177
	INJECTION UNIT		120h			160h			210h			
	Injection speed	mm/s	350			350			350			
	Injection rate (PS)	g/s	116	162	216	162	188	216	162	188	245	311
	Connection power	kW/A	120:14/23 120h:16/27			160:13/22 160h:16/27			210:14/24 210h:19/32			
	Pressure	MPa	17.5			17.5			17.5			
	Flow	l/min	30			30			30			
	Oil tank	l	58			58			58			
Hopper capacity	l	15			15			25				
Machine dimension	m	4.4×1.4×2.1			4.4×1.4×2.1			4.5×1.4×2.1				
Machine weight	t	4.1			4.2			4.2				

NOTE: ¹ Shot volume is the theoretical value which equals to cross section area of screw cylinder or barrel plunger × screw stroke.

² Shot weight (PS) is the theoretical value of shot volume melt density of PS. It is not a measured value.

³ Injection & holding pressure are theoretical values of machine output, not the actual resin pressure.

⁴ Plasticizing capacity(GPPS):GB standard, with application of GPPS plasticizing capacity of 3-zone screws.

This parameter table is based on machine standard configuration;
We reserve the right to make changes as a result of further technical advances.

MACHINE DIMENSIONS

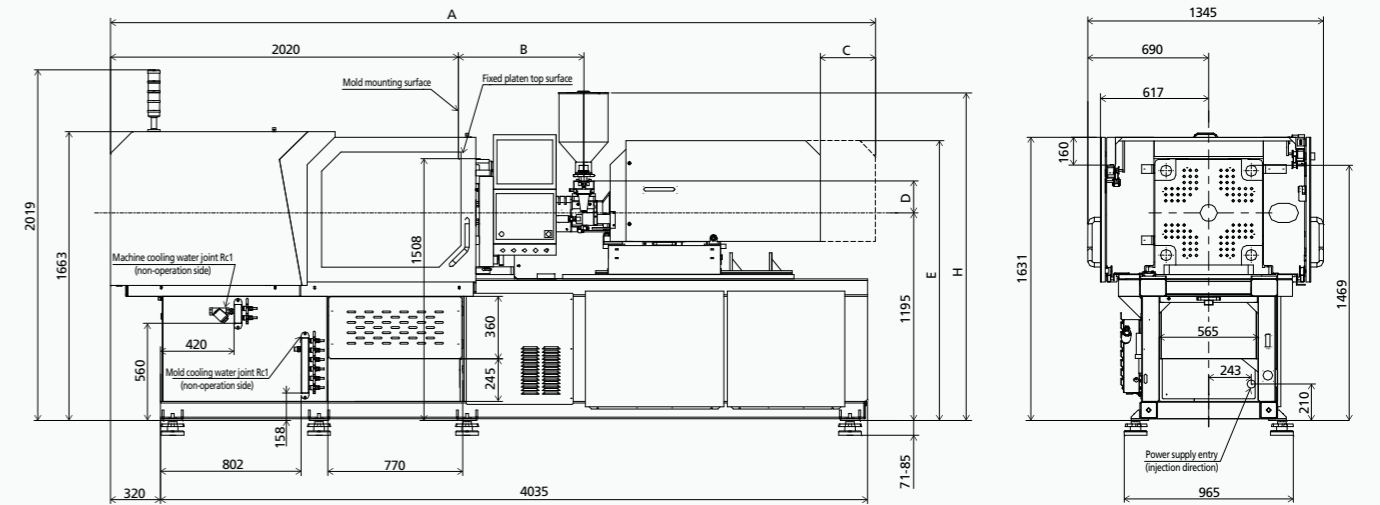

	A	B	C	D	E	F	G	H	I	J	K	L	M	N
120h,120	4274	697	315	184	1600	4×M8 L16	70	1828	95	Ø40	85	107	Ø2.5	SR10
160h,160	4363	697	315	184	1611	4×M8 L16	70	1903	95	Ø40	85	88	Ø2.5	SR10
210h,210	4481	796	315	184	1611	4×M8 L16	70	1903	95	Ø40	85	107	Ø2.5	SR10

PLATEN DIMENSIONS

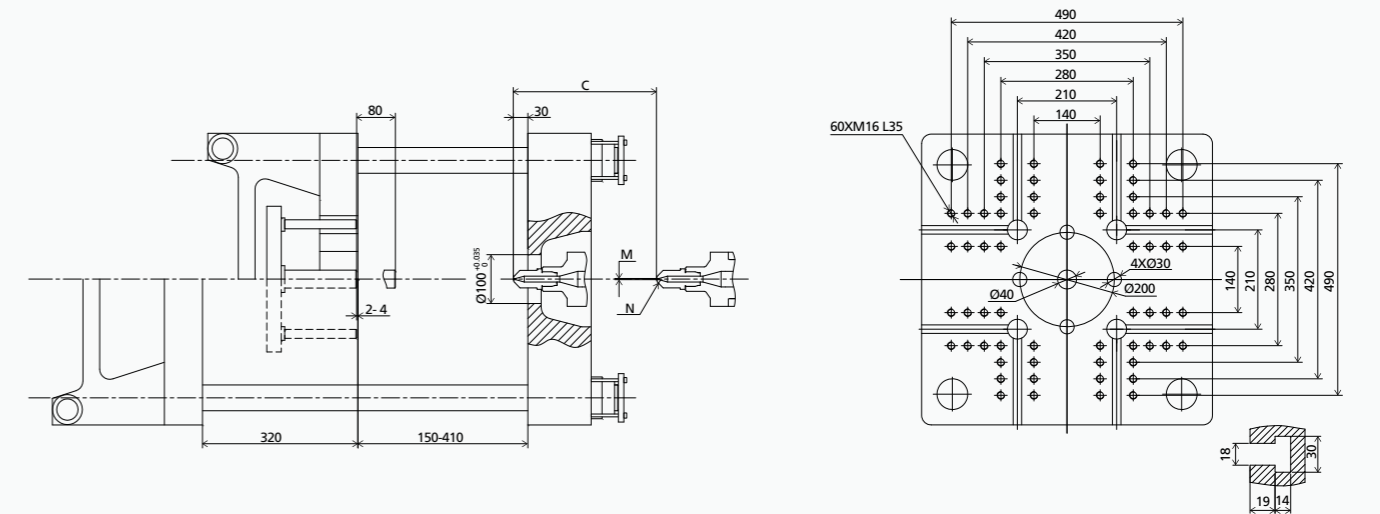

OTHERS DIMENSIONS

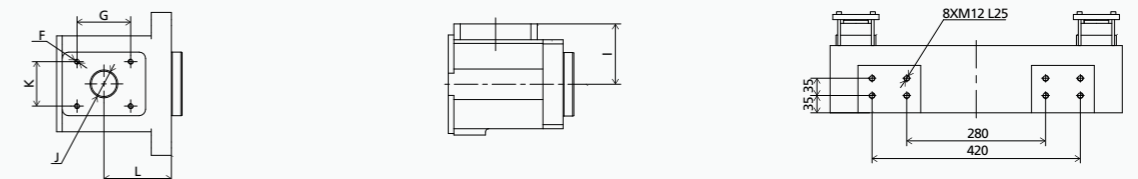

TECHNICAL DATA ZE1200 III

		ZE1200 III														
CLAMPING UNIT	Clamping force	kN	1200													
	Mold opening stroke	mm	360													
	Mold height min.	mm	150													
	Mold height max.	mm	480													
	Max. daylight	mm	840													
	Dist. between tie bars (H×V)	mm	470×470													
	Min. mold dimension	mm	305×305													
	Ejector stroke	mm	100													
	Ejector force	kN	33													
	Size of mold platen (H×V)	mm	690×690													
INJECTION UNIT			A	B	C	AA	A	B	C	AA	A	B	C			
	Screw diameter	mm	26	28	30	26	28	32	36	30	32	36	40	36	40	45
	Screw L/D ratio	L/D	22	21	19	21	21	21	18.6	21	22.5	20	18	23.3	21	18.7
	Injection volume (theoretical) ¹	cm ³	58	67	77	61	70	100	127	102	116	147	182	173	213	270
	Injection weight (PS) ²	g	52	61	70	55	64	91	115	92	106	134	165	157	194	246
	Injection pressure ³	MPa	260	220	192	280	260	200	160	280	253	200	162	247	200	158
		bar	2600	2200	1920	2800	2600	2000	1600	2800	2530	2000	1620	2470	2000	1580
	Holding pressure ³	MPa	160	138	120	224	206	160	126	224	202	160	130	197	160	126
		bar	1600	1380	1200	2240	2060	1600	1206	2240	2020	1600	1300	1970	1600	1260
	Screw speed	rpm	400			400			400			400				
Plasticizing rate (GPPS) ⁴	g/s	8.8	11	13	8.5	11	16	19.4	13.3	16.6	20.1	27.7	22	30	42	
Nozzle contact force	kN	26			26			65			65					
Heating power	kW	7.4	7.4	7.4	6.9	7.8	9.2	9.2	10.4	11.8	11.8	11.8	13.4			
OTHERS	INJECTION UNIT		160			210			300			430(OP)				
	Injection speed	mm/s	200			200			200			200				
	Injection rate (PS)	g/s	92	107	123	92	107	140	177	123	140	177	219	177	219	277
	INJECTION UNIT		160h			210h			300h			430h(OP)				
	Injection speed	mm/s	350			350			300			300				
	Injection rate (PS)	g/s	162	188	216	162	188	245	311	185	210	266	329	266	329	416
	Connection power	kW/A	160:13/22 160h:16/27			210:14/24 210h:19/32			300:18/30 300h:23/38			430:27/46 430h:27/46				
	Pressure	MPa	17.5			17.5			17.5			17.5				
	Flow	l/min	45			45			45			45				
	Oil tank	l	93			93			93			93				
Hopper capacity	l	15			25			25			25					
Machine dimension	m	5.0×1.5×2.2			5.0×1.5×2.2			5.0×1.5×2.2			5.5×1.5×2.2					
Machine weight	t	5.3			5.4			5.7			6.0					

NOTE: ¹ Shot volume is the theoretical value which equals to cross section area of screw cylinder or barrel plunger × screw stroke.

² Shot weight (PS) is the theoretical value of shot volume melt density of PS. It is not a measured value.

³ Injection & holding pressure are theoretical values of machine output, not the actual resin pressure.

⁴ Plasticizing capacity(GPPS):GB standard, with application of GPPS plasticizing capacity of 3-zone screws.

This parameter table is based on machine standard configuration;
We reserve the right to make changes as a result of further technical advances.

MACHINE DIMENSIONS

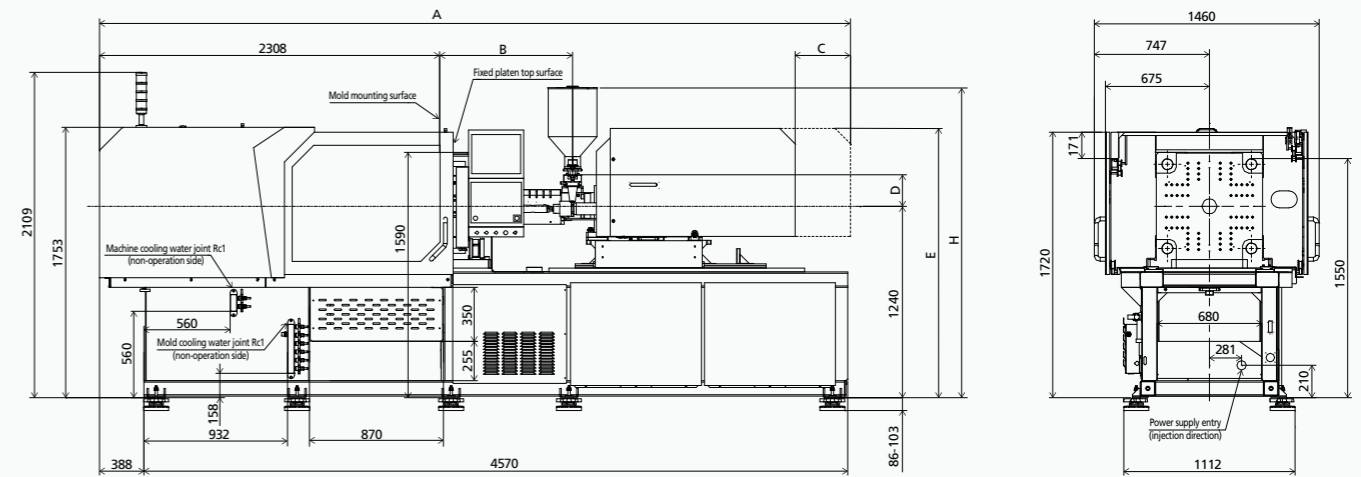

	A	B	C	D	E	F	G	H	I	J	K	L	M	N
160h,160	4651	697	315	184	1656	4×M8 L16	70	1948	95	Ø40	85	88	Ø2.5	SR10
210h,210	4769	796	315	184	1656	4×M8 L16	70	1948	95	Ø40	85	107	Ø2.5	SR10
300h,300	4976	863	360	205	1745	4×M8 L16	70	1969	120	Ø45	85	117	Ø2.5	SR10
430h,430	5463	1013	360	224	1765	4×M8 L16	70	1988	135	Ø50	85	99	Ø3	SR10

PLATEN DIMENSIONS

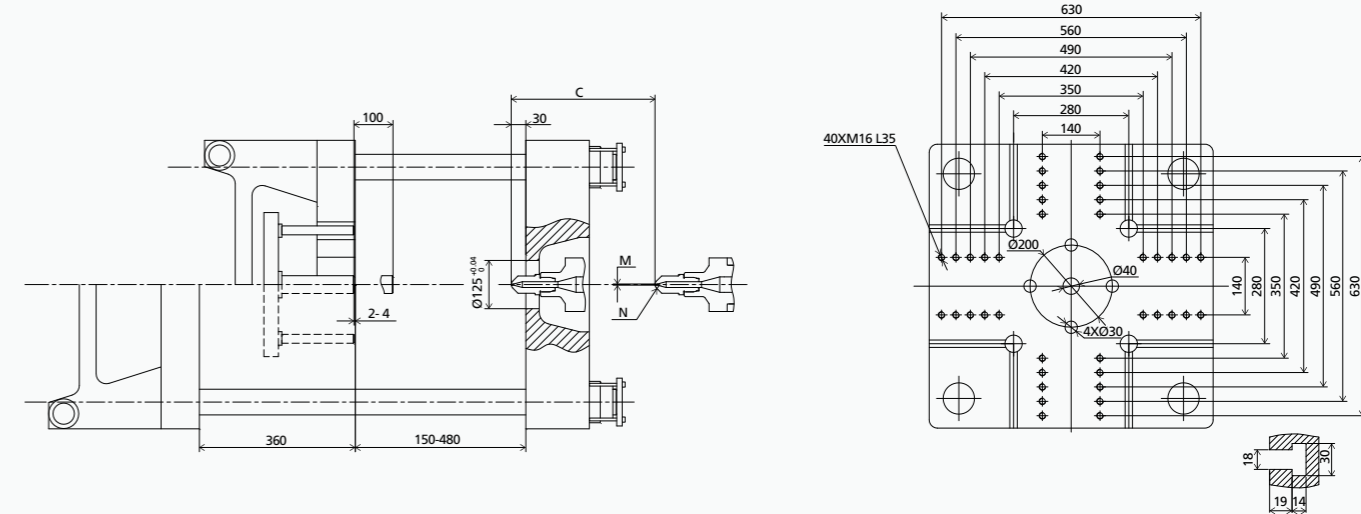

OTHERS DIMENSIONS

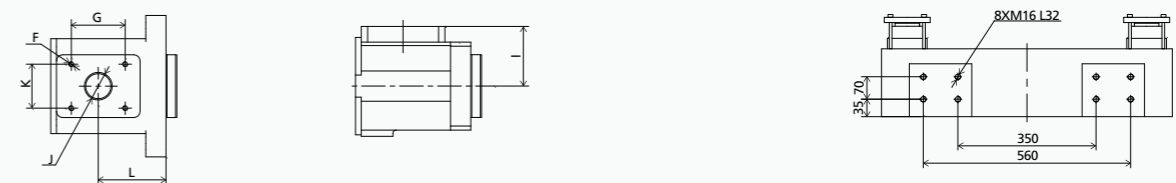

TECHNICAL DATA ZE1500 III

ZE1500 III

		ZE1500 III														
		AA	A	B	C	AA	A	B	C	A	B	C	A	B	C	
CLAMPING UNIT	Clamping force	kN	1500													
	Mold opening stroke	mm	420													
	Mold height min.	mm	180													
	Mold height max.	mm	520													
	Max. daylight	mm	940													
	Dist. between tie bars (H×V)	mm	520×520													
	Min. mold dimension	mm	335×335													
	Ejector stroke	mm	120													
	Ejector force	kN	33													
	Size of mold platen (H×V)	mm	770×770													
INJECTION UNIT	Screw diameter	mm	26	28	32	36	30	32	36	40	36	40	45	40	45	50
	Screw L/D ratio	L/D	21	21	21	18.6	21	22.5	20	18	23.3	21	18.7	22.5	20	18
	Injection volume (theoretical) ¹	cm ³	61	70	100	127	102	116	147	182	173	213	270	252	319	394
	Injection weight (PS) ²	g	55	64	91	115	92	106	134	165	157	194	246	229	290	358
	Injection pressure ³	MPa	280	260	200	160	280	253	200	162	247	200	158	253	200	162
		bar	2800	2600	2000	1600	2800	2530	2000	1620	2470	2000	1580	2530	2000	1620
	Holding pressure ³	MPa	224	206	160	126	224	202	160	130	197	160	126	202	160	130
		bar	2240	2060	1600	1260	2240	2020	1600	1300	1970	1600	1260	2020	1600	1300
	Screw speed	rpm	400			400			400			350				
	Plasticizing rate (GPPS) ⁴	g/s	8.5	11	16	19.4	13.3	16.6	20.1	27.7	22	30	42	27	39	50
Nozzle contact force	kN	26			65			65			65					
Heating power	kW	6.9	7.8	9.2	9.2	10.4	11.8	11.8		13.4			14.8			
OTHERS	INJECTION UNIT		210			300			430			640(OP)				
	Injection speed	mm/s	200			200			200			160				
	Injection rate (PS)	g/s	92	107	140	177	123	140	177	219	177	219	277	175	222	274
	INJECTION UNIT		210h			300h			430h			640h(OP)				
	Injection speed	mm/s	350			300			300			250				
	Injection rate (PS)	g/s	162	188	245	311	185	210	266	329	266	329	416	274	347	428
	Connection power	kW/A	210:14/24 210h:19/32			300:18/30 300h:23/38			430:27/46 430h:27/46			640:28/47 640h:28/47				
	Pressure	MPa	17.5			17.5			17.5			17.5				
	Flow	l/min	45			45			45			45				
	Oil tank	l	93			93			93			93				
Hopper capacity	l	25			25			25			25					
Machine dimension	m	5.4×1.5×2.2			5.4×1.5×2.2			5.8×1.5×2.2			5.9×1.5×2.2					
Machine weight	t	6.6			6.9			7.3			7.3					

NOTE: ¹ Shot volume is the theoretical value which equals to cross section area of screw cylinder or barrel plunger × screw stroke.

² Shot weight (PS) is the theoretical value of shot volume melt density of PS. It is not a measured value.

³ Injection & holding pressure are theoretical values of machine output, not the actual resin pressure.

⁴ Plasticizing capacity(GPPS):GB standard, with application of GPPS plasticizing capacity of 3-zone screws.

This parameter table is based on machine standard configuration;
We reserve the right to make changes as a result of further technical advances.

MACHINE DIMENSIONS

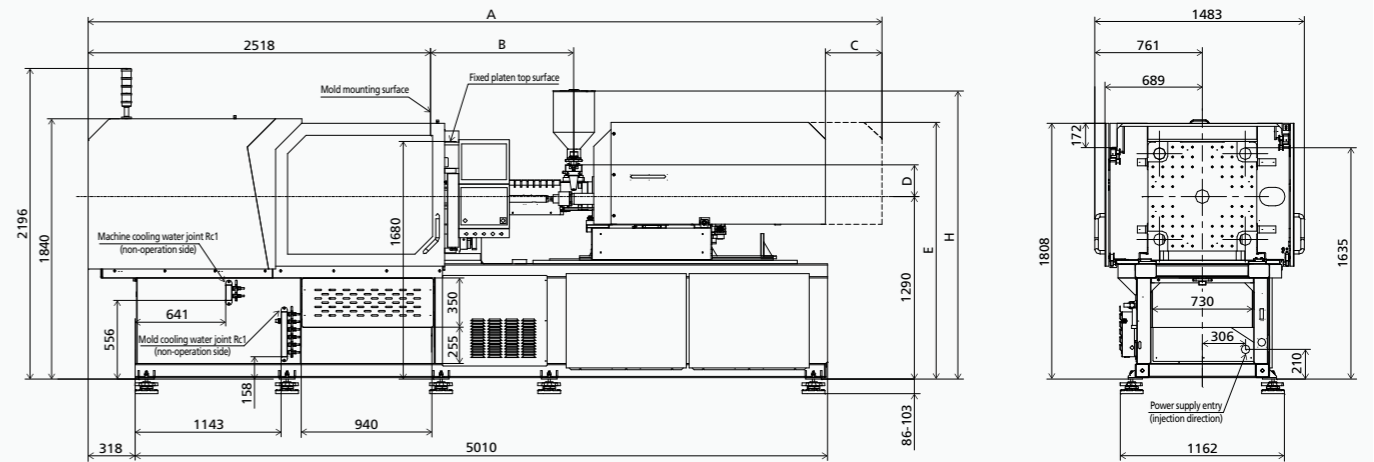

	A	B	C	D	E	F	G	H	I	J	K	L	M	N
210h,210	5064	796	400	184	1706	4×M8 L16	70	1998	95	Ø40	85	107	Ø2.5	SR10
300h,300	5226	863	400	205	1795	4×M8 L16	70	2019	120	Ø45	85	117	Ø2.5	SR10
430h,430	5713	1013	400	224	1815	4×M8 L16	70	2038	135	Ø50	85	99	Ø3	SR10
640h,640	5812	1073	400	214	1815	4×M8 L16	70	2028	125	Ø50	85	138	Ø3	SR10

PLATEN DIMENSIONS

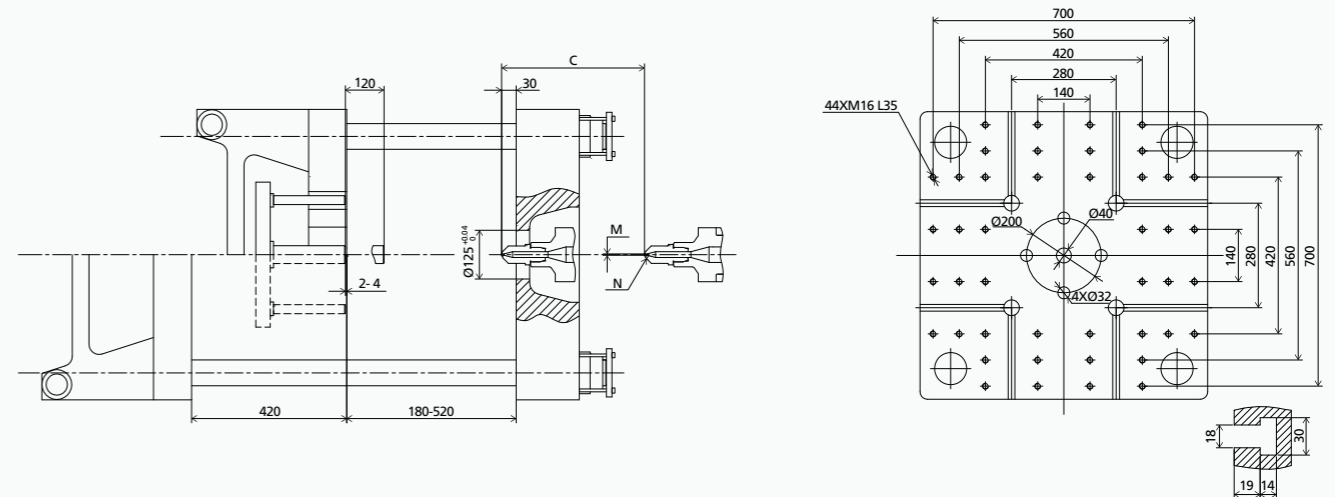

OTHERS DIMENSIONS

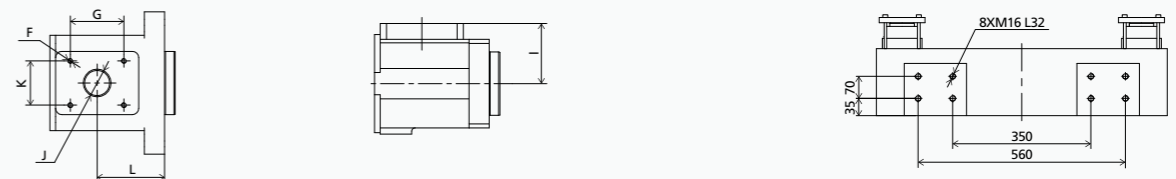

TECHNICAL DATA ZE1900 III

		ZE1900 III																
CLAMPING UNIT	Clamping force	kN	1900															
	Mold opening stroke	mm	470															
	Mold height min.	mm	200															
	Mold height max.	mm	550															
	Max. daylight	mm	1020															
	Dist. between tie bars (H×V)	mm	570×570															
	Min. mold dimension	mm	370×370															
	Ejector stroke	mm	150															
	Ejector force	kN	55															
	Size of mold platen (H×V)	mm	840×840															
INJECTION UNIT	Screw diameter	mm	AA	A	B	C	A	B	C	A	B	C	A	B	C			
		L/D	21	22.5	20	18	23.3	21	18.7	22.5	20	18	22.2	20	18			
	Injection volume (theoretical) ¹	cm ³	102	116	147	182	173	213	270	252	319	394	333	412	498			
		g	92	106	134	165	157	194	246	229	290	358	304	375	454			
	Injection pressure ³	MPa	280	253	200	162	247	200	158	253	200	162	247	200	165			
		bar	2800	2530	2000	1620	2470	2000	1580	2530	2000	1620	2470	2000	1650			
	Holding pressure ³	MPa	224	202	160	130	197	160	126	202	160	130	197	160	132			
		bar	2240	2020	1600	1300	1970	1600	1260	2020	1600	1300	1970	1600	1320			
	Screw speed	rpm	400			400			350			320						
	Plasticizing rate (GPPS) ⁴	g/s	13.3	16.6	20.1	27.7	22	30	42	27	39	50	35	46	60			
	Nozzle contact force	kN	65			65			65			85						
	Heating power	kW	10.4	11.8	11.8	11.8	13.4			14.8			20.2					
	INJECTION UNIT		300				430				640				830(OP)			
		Injection speed	mm/s	200				200				160				160		
	Injection rate (PS)	g/s	123	140	177	219	177	219	277	175	222	274	222	274	332			
	INJECTION UNIT		300h				430h				640h				830h(OP)			
		Injection speed	mm/s	300				300				250				250		
	Injection rate (PS)	g/s	185	210	266	329	266	329	416	274	347	428	347	428	518			
Connection power	kW/A	300:18/30 300h:23/38				430:27/46 430h:27/46				640:28/47 640h:28/47				830:36/60 830h:36/60				
	Pressure	MPa	17.5				17.5				17.5				17.5			
Flow	l/min	74				74				74				74				
Oil tank	l	115				115				115				115				
Hopper capacity	l	25				25				25				50				
Machine dimension	m	6.0×1.6×2.3				6.1×1.6×2.3				6.2×1.6×2.3				6.4×1.6×2.3				
Machine weight	t	8.5				8.7				8.9				9.5				

NOTE: ¹ Shot volume is the theoretical value which equals to cross section area of screw cylinder or barrel plunger × screw stroke.
² Shot weight (PS) is the theoretical value of shot volume melt density of PS. It is not a measured value.
³ Injection & holding pressure are theoretical values of machine output, not the actual resin pressure.
⁴ Plasticizing capacity(GPPS):GB standard, with application of GPPS plasticizing capacity of 3-zone screws.

This parameter table is based on machine standard configuration;
 We reserve the right to make changes as a result of further technical advances.

MACHINE DIMENSIONS

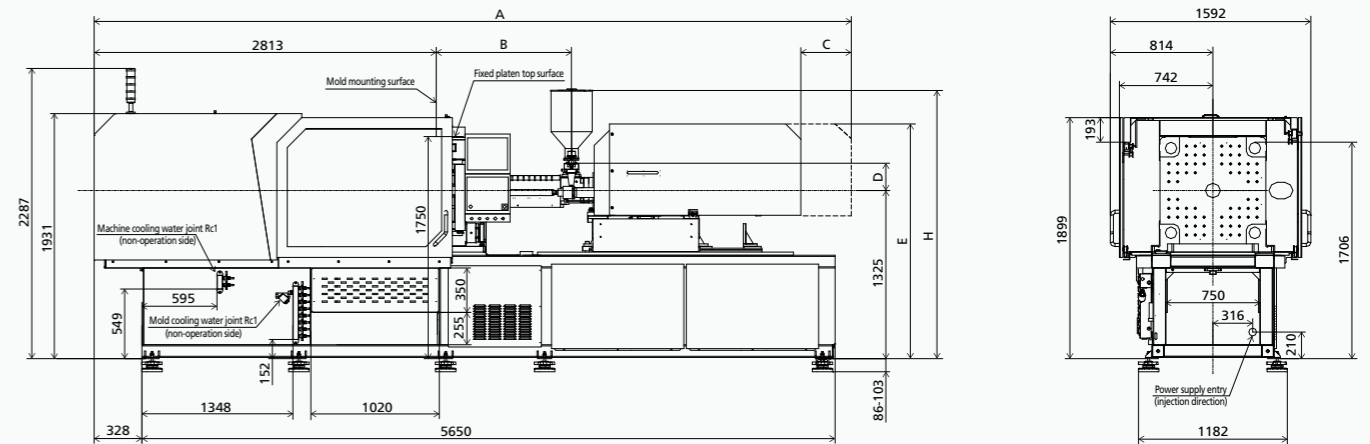

	A	B	C	D	E	F	G	H	I	J	K	L	M	N
300h,300	5521	863	400	205	1830	4×M8 L16	70	2054	120	Ø45	85	117	Ø2.5	SR10
430h,430	6008	1013	400	224	1850	4×M8 L16	70	2073	135	Ø50	85	99	Ø3	SR10
640h,640	6107	1073	400	214	1850	4×M8 L16	70	2063	125	Ø50	85	138	Ø3	SR10
830h,830	6388	1184	430	255	2019	4×M10 L20	115	2183	153	Ø60	115	122.5	Ø3	SR10

PLATEN DIMENSIONS

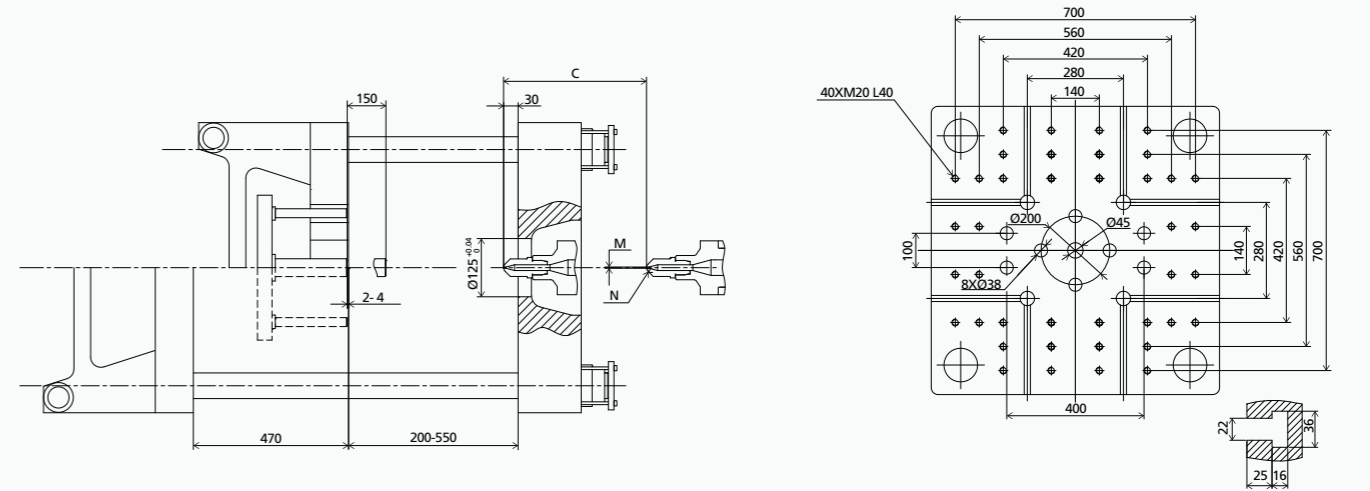

OTHERS DIMENSIONS

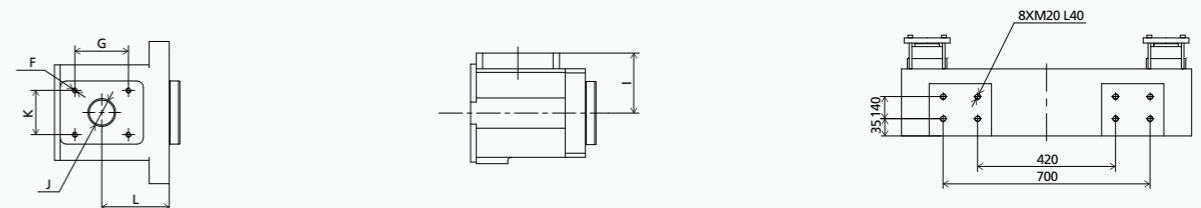

TECHNICAL DATA ZE2300 III

ZE2300 III

CLAMPING UNIT		ZE2300 III											
Clamping force	kN	2300											
Mold opening stroke	mm	550											
Mold height min.	mm	220											
Mold height max.	mm	600											
Max. daylight	mm	1150											
Dist. between tie bars (H×V)	mm	620×620											
Min. mold dimension	mm	400×400											
Ejector stroke	mm	150											
Ejector force	kN	55											
Size of mold platen (H×V)	mm	920×920											
		A	B	C	A	B	C	A	B	C	A	B	C
Screw diameter	mm	36	40	45	40	45	50	45	50	55	50	55	60
Screw L/D ratio	L/D	23.3	21	18.7	22.5	20	18	22.2	20	18	22	20	18.3
Injection volume (theoretical) ¹	cm ³	173	213	270	252	319	394	333	412	498	471	570	678
Injection weight (PS) ²	g	157	194	246	229	290	358	304	375	454	428	518	617
Injection pressure ³	MPa	247	200	158	253	200	162	247	200	165	218	180	151
	bar	2470	2000	1580	2530	2000	1620	2470	2000	1650	2180	1800	1510
Holding pressure ³	MPa	197	160	126	202	160	130	197	160	132	194	160	134
	bar	1970	1600	1260	2020	1600	1300	1970	1600	1320	1940	1600	1340
Screw speed	rpm	400			350			320			320		
Plasticizing rate (GPPS) ⁴	g/s	22	30	42	27	39	50	35	46	60	52	64	75
Nozzle contact force	kN	65			65			85			85		
Heating power	kW	13.4			14.8			20.2			25		
INJECTION UNIT		430			640			830			1100(OP)		
Injection speed	mm/s	200			160			160			160		
Injection rate (PS)	g/s	177	219	277	175	222	274	222	274	332	274	332	395
INJECTION UNIT		430h			640h			830h			1100h(OP)		
Injection speed	mm/s	300			250			250			250		
Injection rate (PS)	g/s	266	329	416	274	347	428	347	428	518	428	518	617
Connection power	kW/A	430:27/46 430h:27/46			640:28/47 640h:28/47			830:36/60 830h:36/60			1100:44/73 1100h:44/73		
Pressure	MPa	17.5			17.5			17.5			17.5		
Flow	l/min	74			74			74			74		
Oil tank	l	122			122			122			122		
Hopper capacity	l	25			25			50			50		
Machine dimension	m	6.5×1.8×2.4			6.5×1.8×2.4			6.7×1.8×2.4			6.9×1.8×2.4		
Machine weight	t	11.4			11.5			11.9			12.1		

INJECTION UNIT

OTHERS

NOTE: ¹ Shot volume is the theoretical value which equals to cross section area of screw cylinder or barrel plunger × screw stroke.
² Shot weight (PS) is the theoretical value of shot volume melt density of PS. It is not a measured value.
³ Injection & holding pressure are theoretical values of machine output, not the actual resin pressure.
⁴ Plasticizing capacity(GPPS):GB standard, with application of GPPS plasticizing capacity of 3-zone screws.

This parameter table is based on machine standard configuration;
 We reserve the right to make changes as a result of further technical advances.

MACHINE DIMENSIONS

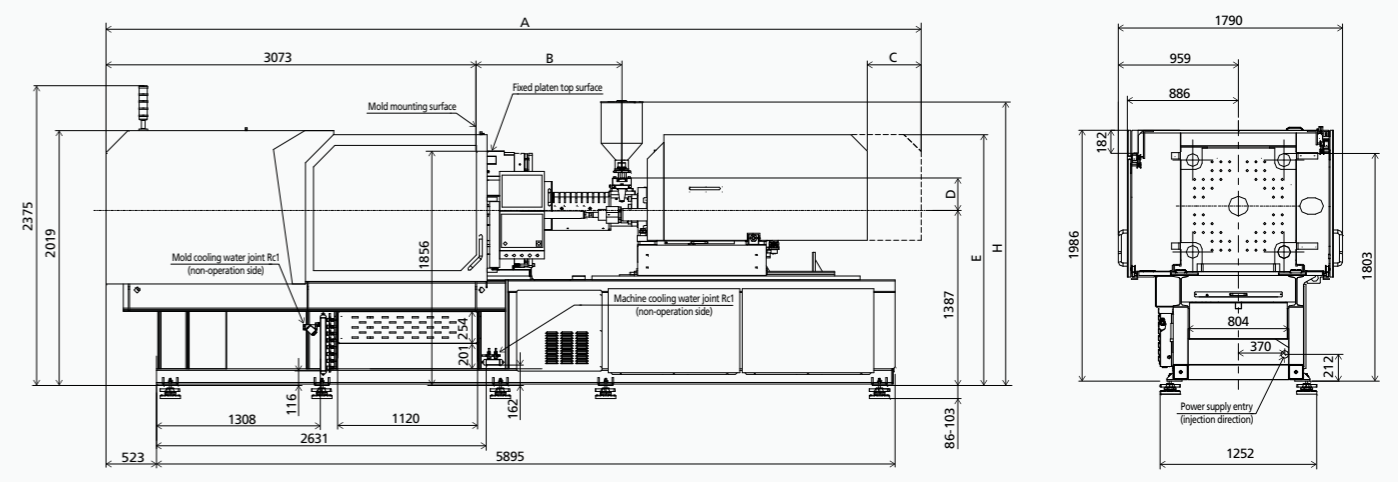

	A	B	C	D	E	F	G	H	I	J	K	L	M	N
430h,430	6268	1013	400	224	1912	4×M8 L16	70	2135	135	Ø50	85	99	Ø3	SR10
640h,640	6368	1073	400	214	1912	4×M8 L16	70	2125	125	Ø50	85	138	Ø3	SR10
830h,830	6648	1184	430	255	2080	4×M10 L20	115	2245	153	Ø60	115	122.5	Ø3	SR10
1100h,1100	6821	1300	430	245	2080	4×M10 L20	115	2235	143	Ø60	115	180	Ø3	SR10

PLATEN DIMENSIONS

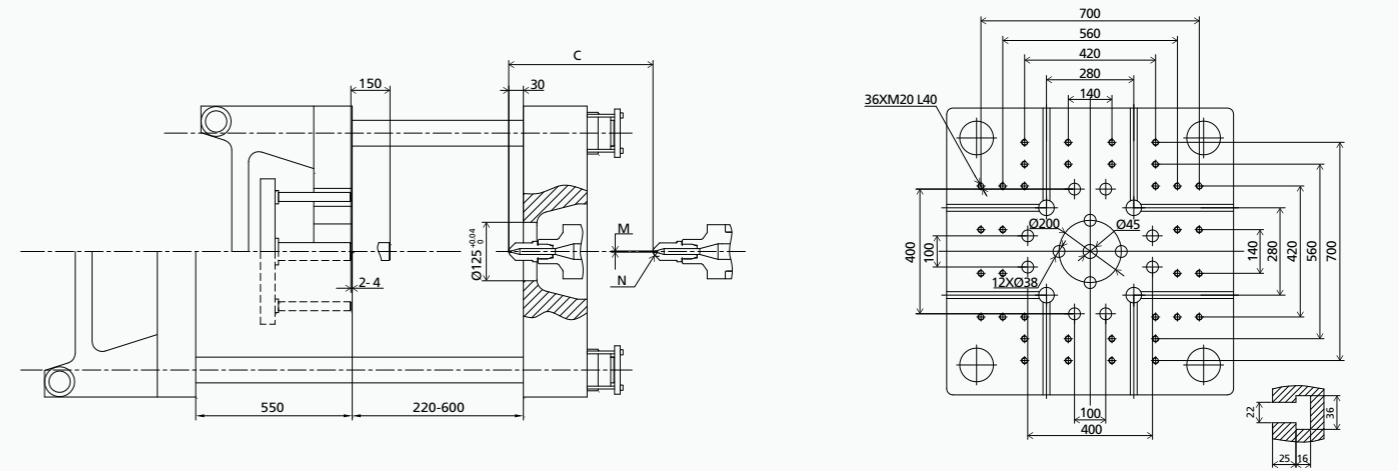

OTHERS DIMENSIONS

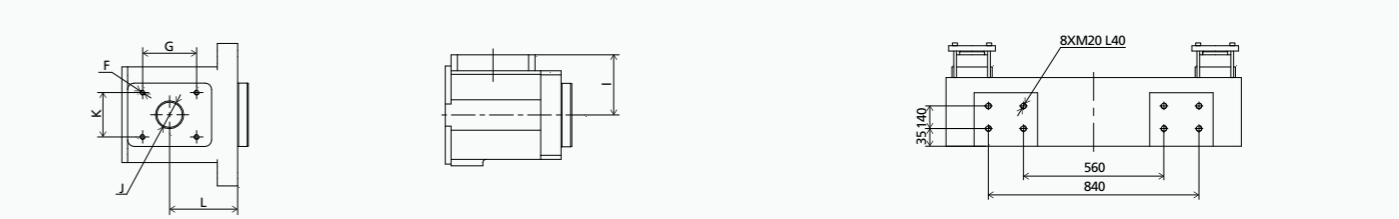

TECHNICAL DATA ZE3000 III

ZE3000 III

CLAMPING UNIT		ZE3000 III											
Clamping force	kN	3000											
Mold opening stroke	mm	600											
Mold height min.	mm	280											
Mold height max.	mm	650											
Max. daylight	mm	1250											
Dist. between tie bars (H×V)	mm	730×730											
Min. mold dimension	mm	470×470											
Ejector stroke	mm	160											
Ejector force	kN	68.6											
Size of mold platen (H×V)	mm	1040×1040											
		A	B	C	A	B	C	A	B	C	A	B	C
Screw diameter	mm	45	50	55	50	55	60	55	60	65	60	65	70
Screw L/D ratio	L/D	22.2	20	18	22	20	18.3	21.8	20	18.5	21.6	20	18.6
Injection volume (theoretical) ¹	cm ³	333	412	498	471	570	678	617	735	862	791	929	1077
Injection weight (PS) ²	g	304	375	454	428	518	617	562	668	785	720	845	980
Injection pressure ³	MPa	247	200	165	218	180	151	214	180	153	210	180	155
	bar	2470	2000	1650	2180	1800	1510	2140	1800	1530	2100	1800	1550
Holding pressure ³	MPa	197	160	132	194	160	134	190	160	136	187	160	138
	bar	1970	1600	1320	1940	1600	1340	1900	1600	1360	1870	1600	1380
Screw speed	rpm	320			320			300			250		
Plasticizing rate (GPPS) ⁴	g/s	35	46	60	52	64	75	54	64	71	57	68	72
Nozzle contact force	kN	85			85			85			85		
Heating power	kW	20.2			25			29.7			34.3		
INJECTION UNIT		830			1100			1400			1700(OP)		
Injection speed	mm/s	160			160			160			160		
Injection rate (PS)	g/s	222	274	332	274	332	395	332	395	463	395	463	537
INJECTION UNIT		830h			1100h			1400h			1700h(OP)		
Injection speed	mm/s	250			250			250			250		
Injection rate (PS)	g/s	347	428	518	428	518	617	518	617	724	617	724	840
Connection power	kW/A	830:36/60 830h:36/60			1100:44/73 1100h:44/73			1400:53/90 1400h:56/94			1700:56/93 1700h:59/98		
Pressure	MPa	17.5			17.5			17.5			17.5		
Flow	l/min	90			90			90			90		
Oil tank	l	135			135			135			135		
Hopper capacity	l	50			50			50			50		
Machine dimension	m	7.0×2.1×2.5			7.1×2.1×2.5			7.5×2.1×2.5			7.7×2.1×2.5		
Machine weight	t	14.6			14.7			16.1			16.2		

INJECTION UNIT

OTHERS

NOTE: ¹ Shot volume is the theoretical value which equals to cross section area of screw cylinder or barrel plunger × screw stroke.
² Shot weight (PS) is the theoretical value of shot volume melt density of PS. It is not a measured value.
³ Injection & holding pressure are theoretical values of machine output, not the actual resin pressure.
⁴ Plasticizing capacity(GPPS):GB standard, with application of GPPS plasticizing capacity of 3-zone screws.

This parameter table is based on machine standard configuration;
 We reserve the right to make changes as a result of further technical advances.

MACHINE DIMENSIONS

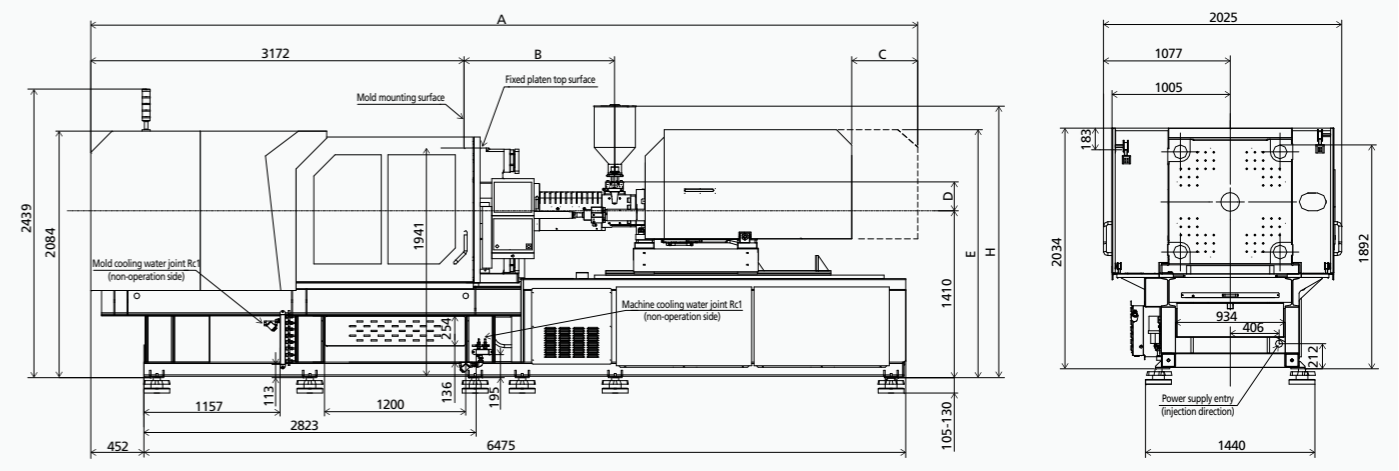

	A	B	C	D	E	F	G	H	I	J	K	L	M	N
830h,830	6878	1184	560	255	2009	4×M10 L20	115	2268	153	Ø60	115	122.5	Ø3	SR10
1100h,1100	7051	1300	560	245	2009	4×M10 L20	115	2258	143	Ø60	115	180	Ø3	SR10
1400h,1400	7427	1382	560	251	2115	4×M10 L20	115	2264	149	Ø80	115	184	Ø3	SR10
1700h,1700	7625	1547	560	250	2115	4×M10 L20	115	2264	148	Ø80	115	217	Ø3	SR10

PLATEN DIMENSIONS

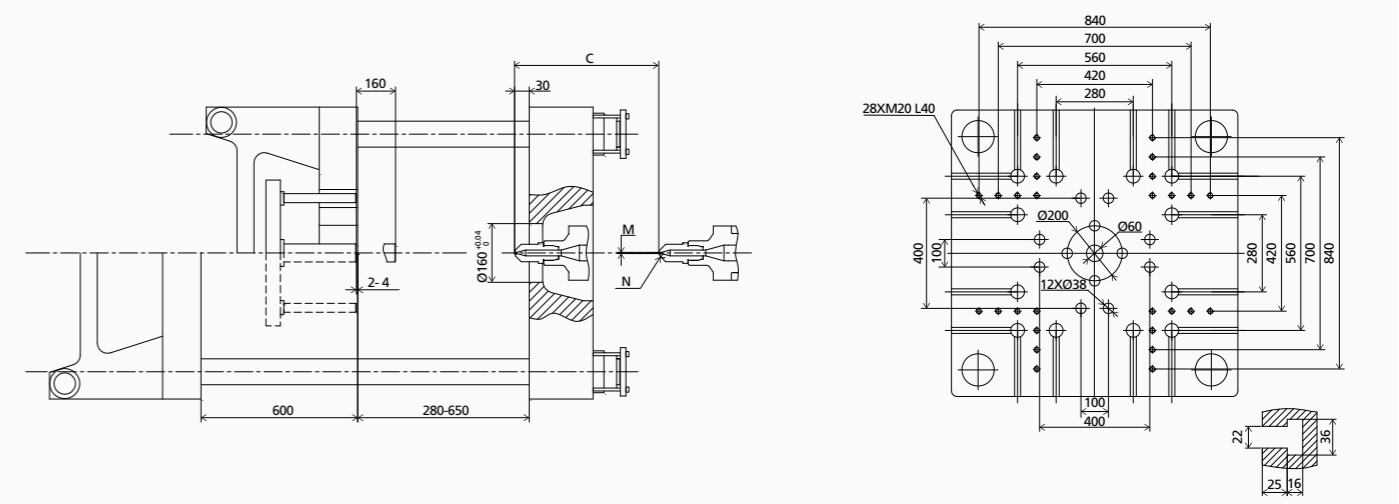

OTHERS DIMENSIONS



TECHNICAL DATA ZE3600 III

		ZE3600 III												
CLAMPING UNIT	Clamping force	kN	3600											
	Mold opening stroke	mm	730											
	Mold height min.	mm	320											
	Mold height max.	mm	710											
	Max. daylight	mm	1440											
	Dist. between tie bars (H×V)	mm	820×820											
	Min. mold dimension	mm	540×540											
	Ejector stroke	mm	160											
	Ejector force	kN	68.6											
	Size of mold platen (H×V)	mm	1170×1170											
INJECTION UNIT	Screw diameter	mm	A	B	C	A	B	C	A	B	C	A	B	C
		50	55	60	55	60	65	60	65	70	65	70	80	
		L/D	22	20	18.3	21.8	20	18.5	21.6	20	18.6	21.5	20	17.5
	Injection volume (theoretical) ¹	cm ³	471	570	678	617	735	862	791	929	1077	1068	1239	1618
		g	428	518	617	562	668	785	720	845	980	972	1127	1472
	Injection pressure ³	MPa	218	180	151	214	180	153	210	180	155	210	180	138
		bar	2180	1800	1510	2140	1800	1530	2100	1800	1550	2100	1800	1380
	Holding pressure ³	MPa	194	160	134	190	160	136	187	160	138	190	162	124
		bar	1940	1600	1340	1900	1600	1360	1870	1600	1380	1900	1620	1240
	Screw speed	rpm	320			300			250			210		
Plasticizing rate (GPPS) ⁴	g/s	52	64	75	54	64	71	57	68	72	56	65	80	
Plasticizing rate (HDPE) ⁵	g/s	-	-	-	-	-	-	-	-	-	80	95	120	
Nozzle contact force	kN	85			85			85			85			
Heating power	kW	25			29.7			34.3			37.6			
OTHERS	INJECTION UNIT		1100			1400			1700			2250(OP)		
	Injection speed	mm/s	160			160			160			160		
	Injection rate (PS)	g/s	274	332	395	332	395	463	395	463	537	463	537	702
	INJECTION UNIT		1100h			1400h			1700h			2250h(OP)		
	Injection speed	mm/s	250			250			250			250		
	Injection rate (PS)	g/s	428	518	617	518	617	724	617	724	840	723	839	1097
	Connection power	kW/A	1100:44/73 1100h:44/73			1400:53/90 1400h:56/94			1700:56/93 1700h:59/98			2250:73/122 2250h:106/177		
	Pressure	MPa	17.5			17.5			17.5			17.5		
	Flow	l/min	90			90			90			90		
	Oil tank	l	135			135			135			135		
Hopper capacity	l	50			50			50			50			
Machine dimension	m	7.5×2.2×2.6			7.8×2.2×2.6			8.0×2.2×2.6			7.9×2.2×2.6			
Machine weight	t	17.4			18.4			18.5			20.5			

NOTE: ¹ Shot volume is the theoretical value which equals to cross section area of screw cylinder or barrel plunger × screw stroke.
² Shot weight (PS) is the theoretical value of shot volume melt density of PS. It is not a measured value.
³ Injection & holding pressure are theoretical values of machine output, not the actual resin pressure.
⁴ Plasticizing capacity(GPPS):GB standard, with application of GPPS plasticizing capacity of 3-zone screws.
⁵ Plasticizing capacity(HDPE):Euromap 19, with application of HDPE plasticizing capacity of barrier screws.

This parameter table is based on machine standard configuration;
 We reserve the right to make changes as a result of further technical advances.

MACHINE DIMENSIONS

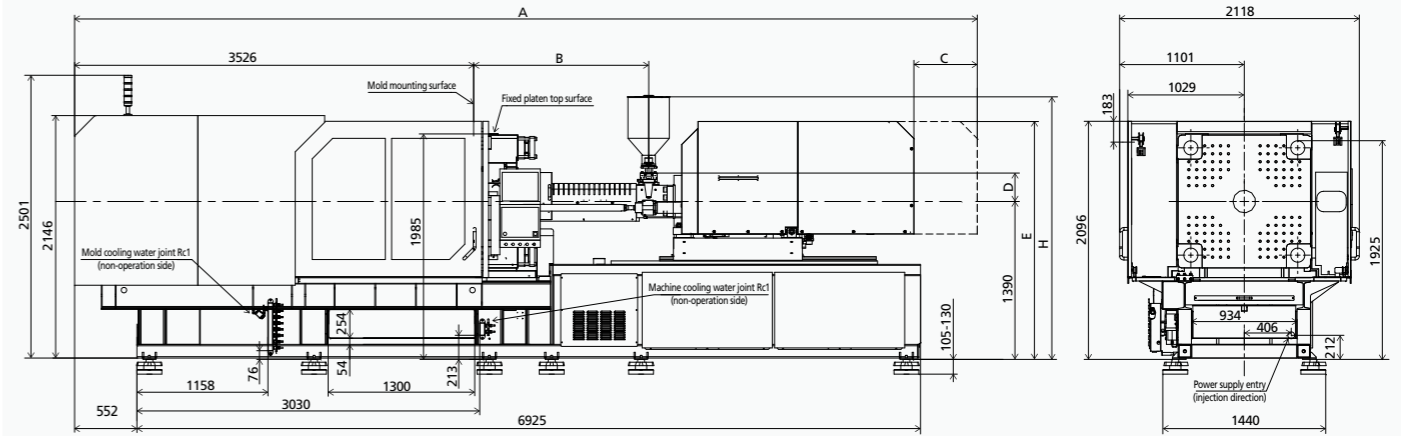

	A	B	C	D	E	F	G	H	I	J	K	L	M	N
1100h,1100	7404	1300	560	245	1990	4×M10 L20	115	2238	143	∅60	115	180	∅3	SR10
1400h,1400	7780	1382	560	251	2095	4×M10 L20	115	2244	149	∅80	115	184	∅3	SR10
1700h,1700	7978	1547	560	250	2095	4×M10 L20	115	2244	148	∅80	115	217	∅3	SR10

PLATEN DIMENSIONS

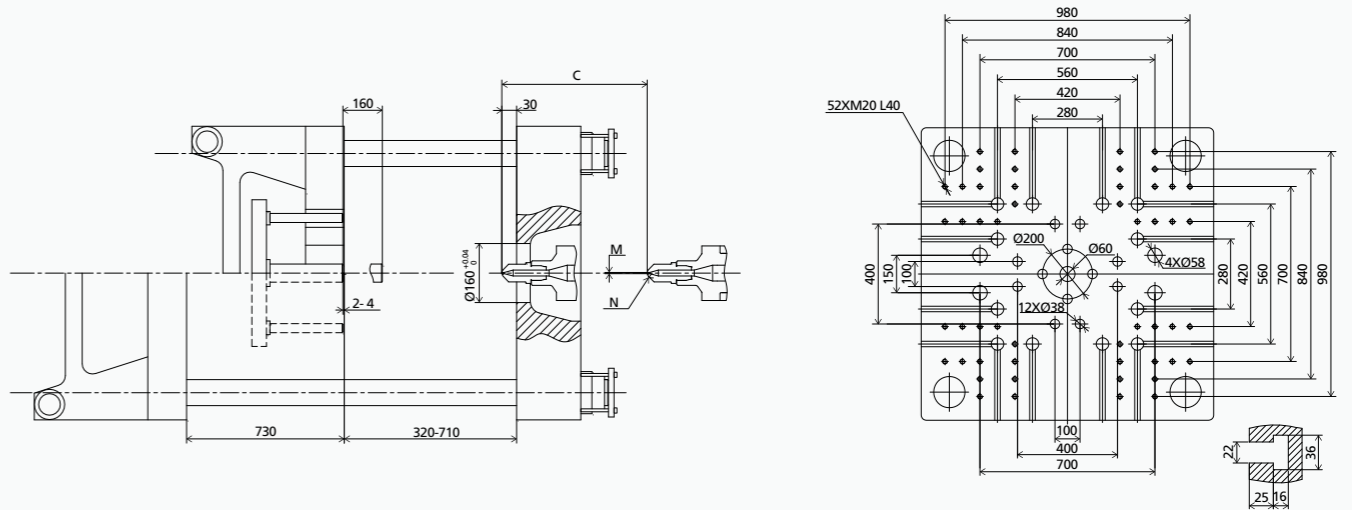

OTHERS DIMENSIONS

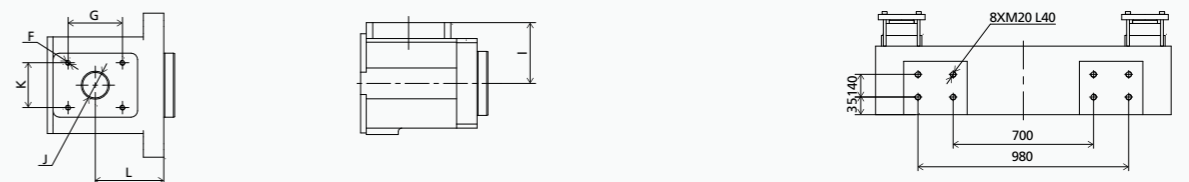

PLATEN LAYOUT ZE400 III

PLATEN LAYOUT ZE600 III

EUROPEAN VERSION FIXED PLATEN

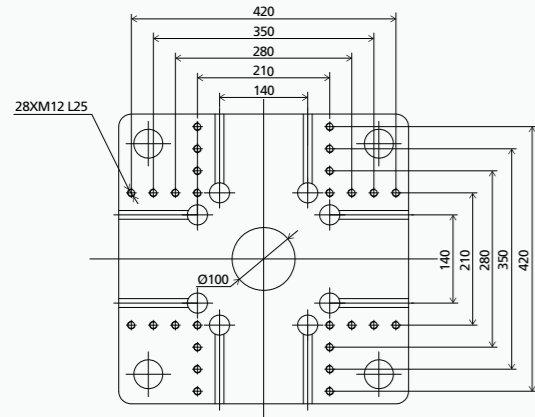

MOVABLE PLATEN

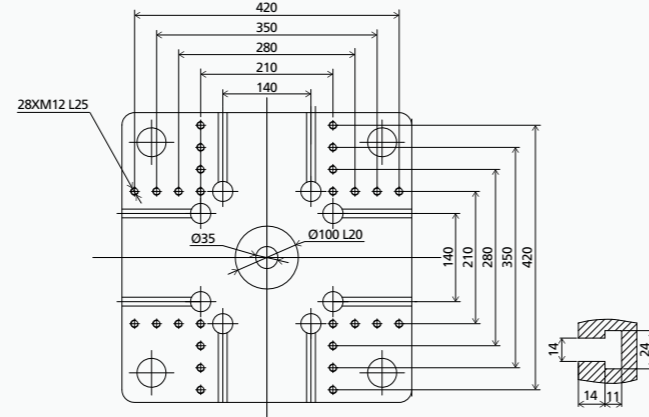

EUROPEAN VERSION FIXED PLATEN

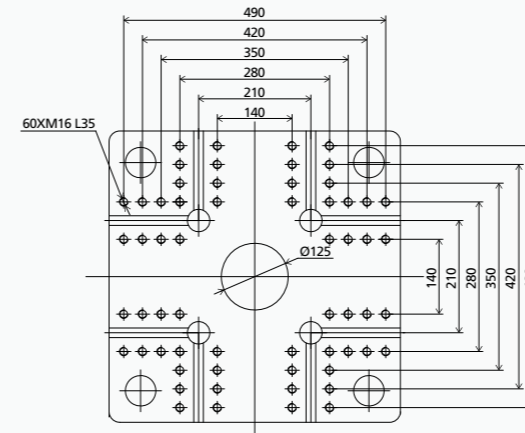

MOVABLE PLATEN

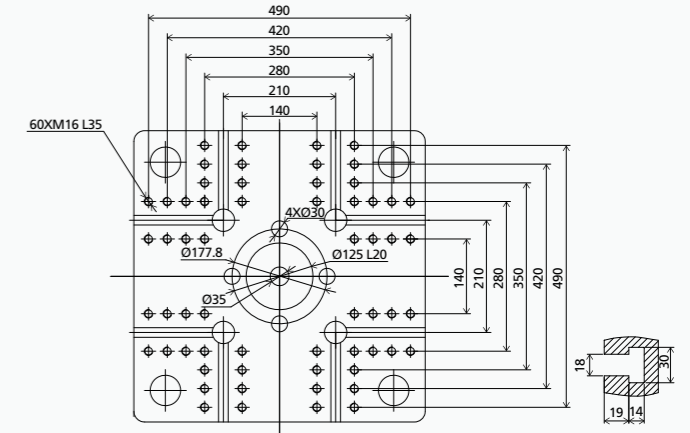

AMERICAN VERSION FIXED PLATEN

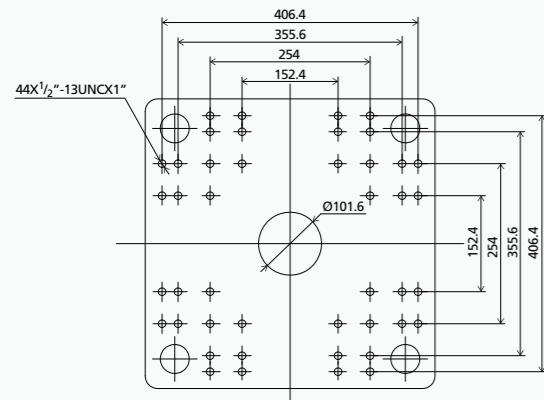

MOVABLE PLATEN

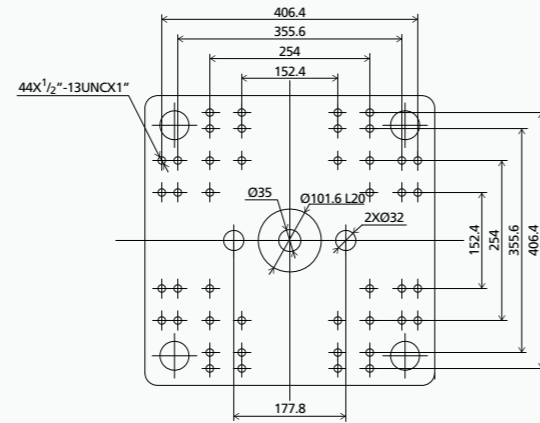

AMERICAN VERSION FIXED PLATEN

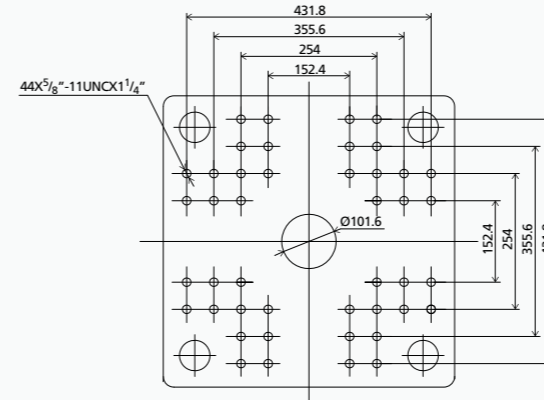

MOVABLE PLATEN

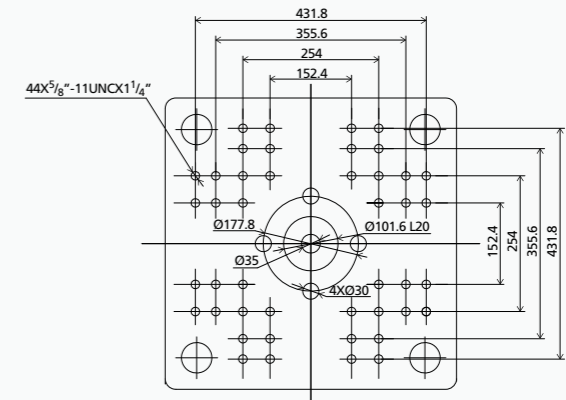

JAPANESE VERSION FIXED PLATEN

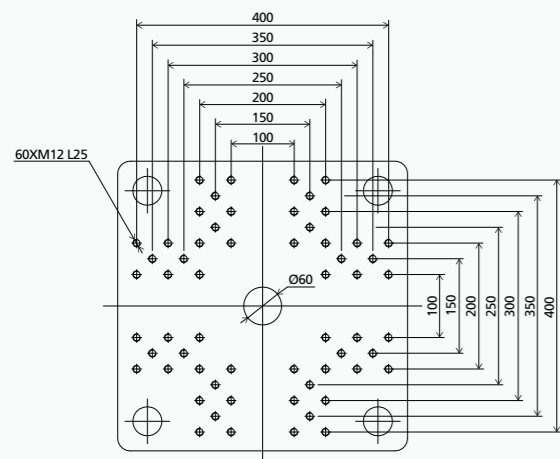

MOVABLE PLATEN

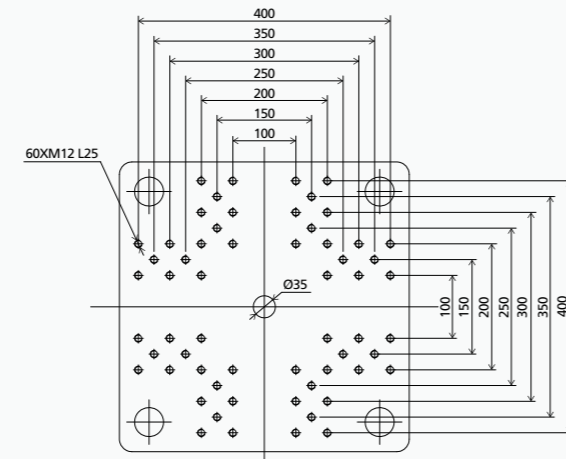

JAPANESE VERSION FIXED PLATEN

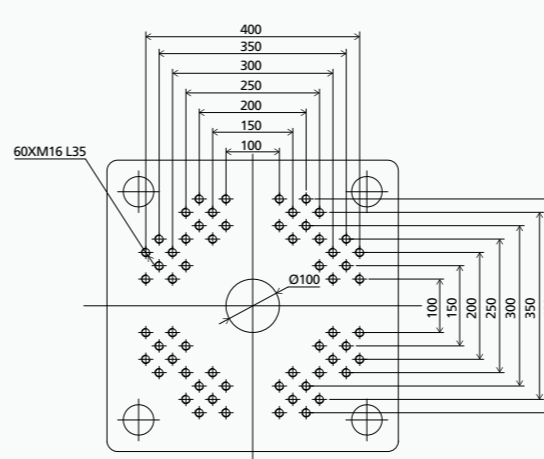

MOVABLE PLATEN

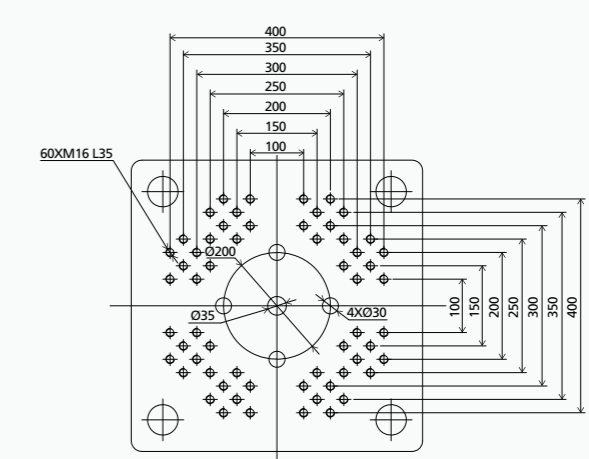

We reserve the right to make changes as a result of further technical advances.

PLATEN LAYOUT ZE900 III

EUROPEAN VERSION FIXED PLATEN

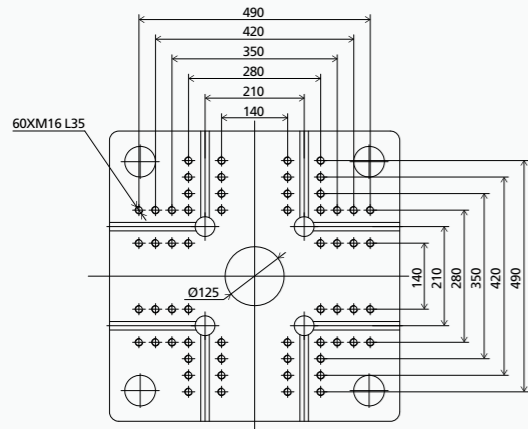

MOVABLE PLATEN

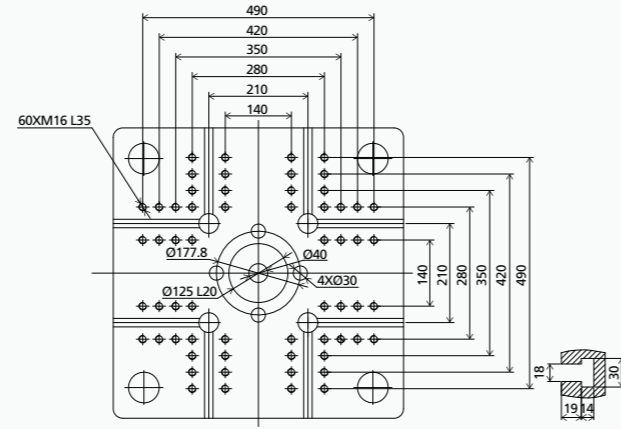

EUROPEAN VERSION FIXED PLATEN

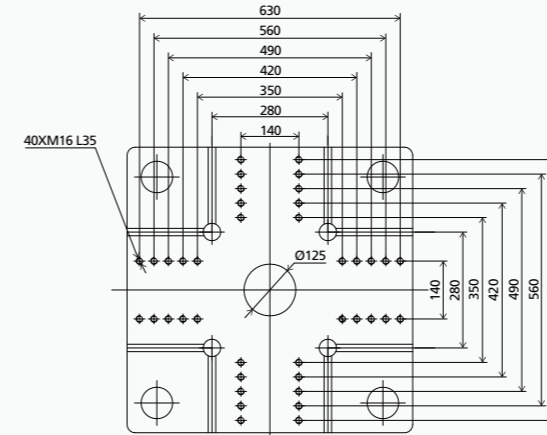

MOVABLE PLATEN

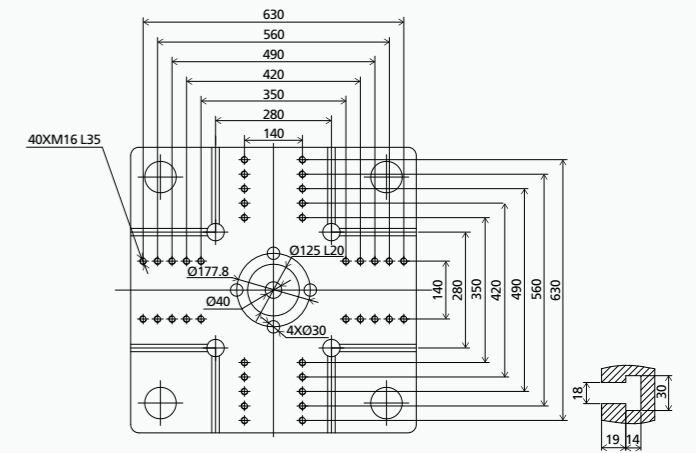

AMERICAN VERSION FIXED PLATEN

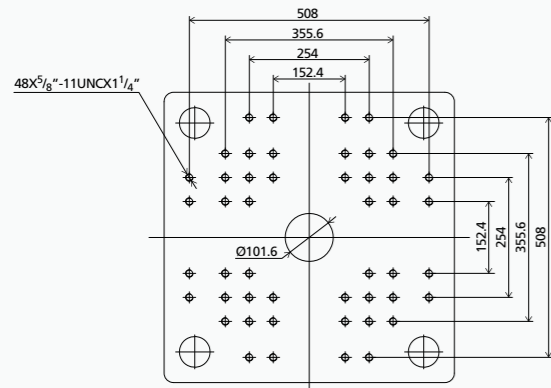

MOVABLE PLATEN

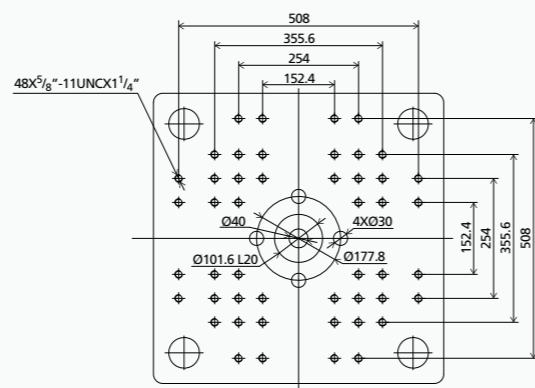

AMERICAN VERSION FIXED PLATEN

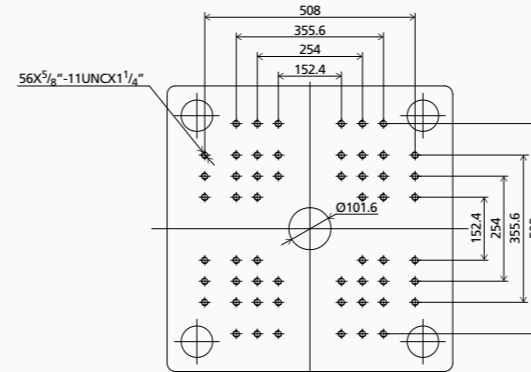

MOVABLE PLATEN

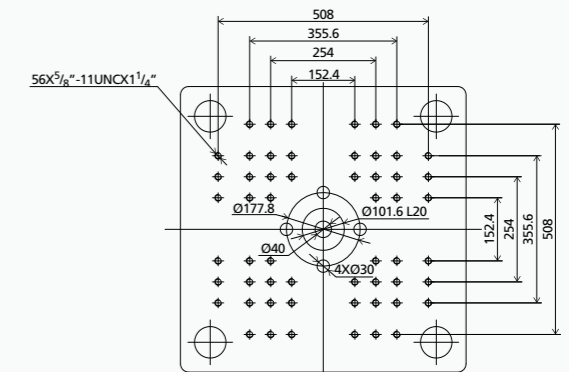

JAPANESE VERSION FIXED PLATEN

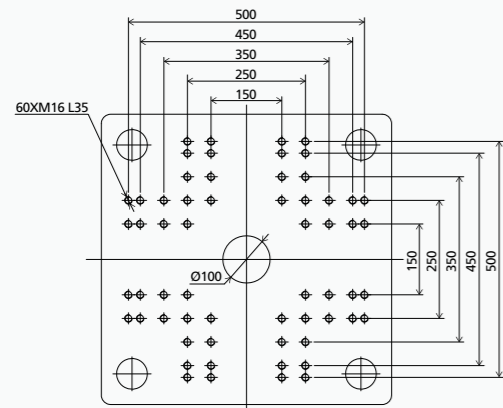

MOVABLE PLATEN

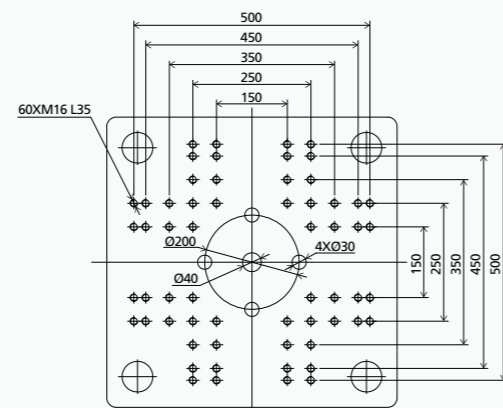

JAPANESE VERSION FIXED PLATEN

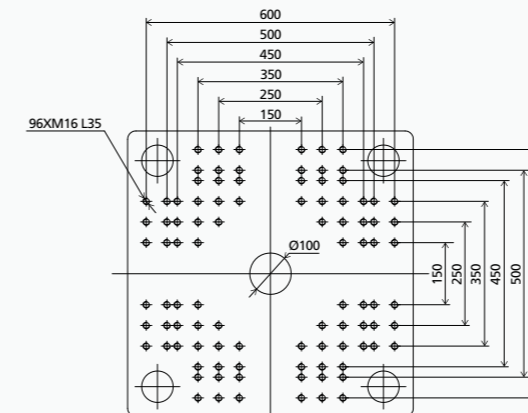

MOVABLE PLATEN

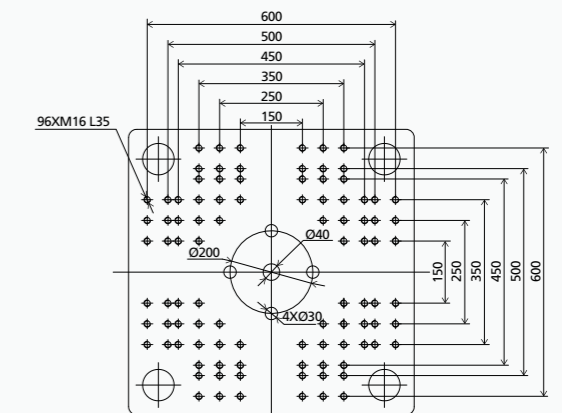

We reserve the right to make changes as a result of further technical advances.

PLATEN LAYOUT ZE1500 III

EUROPEAN VERSION FIXED PLATEN

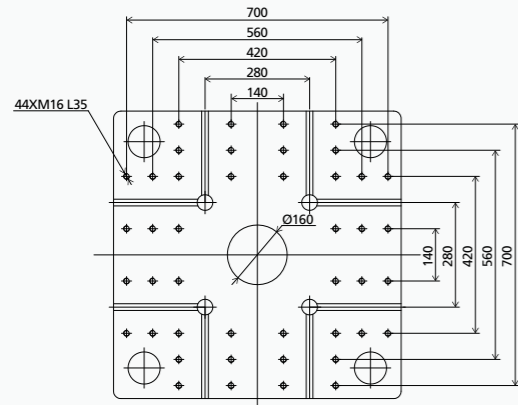

MOVABLE PLATEN

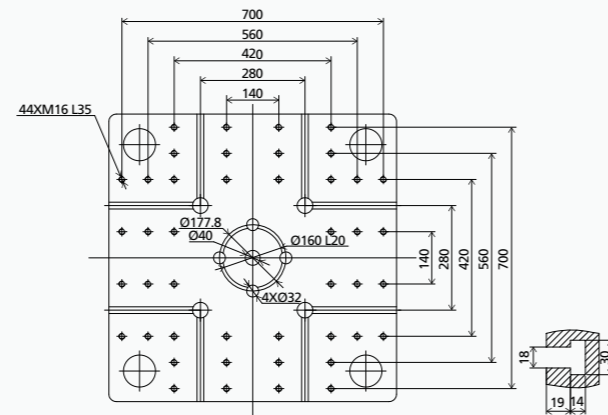

EUROPEAN VERSION FIXED PLATEN

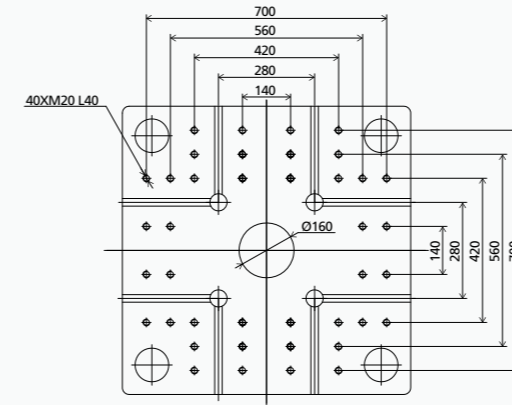

MOVABLE PLATEN

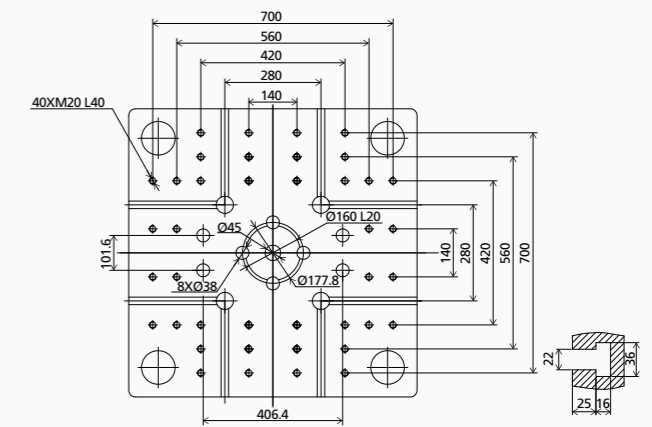

AMERICAN VERSION FIXED PLATEN

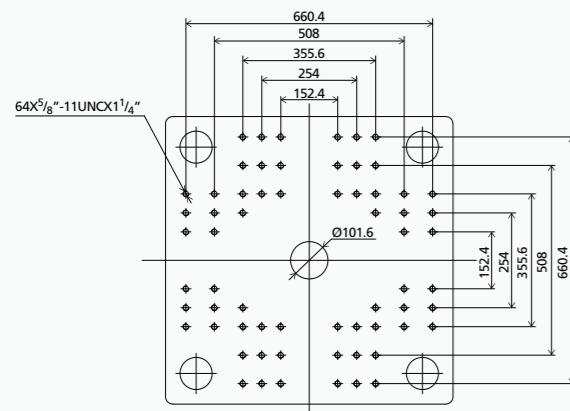

MOVABLE PLATEN

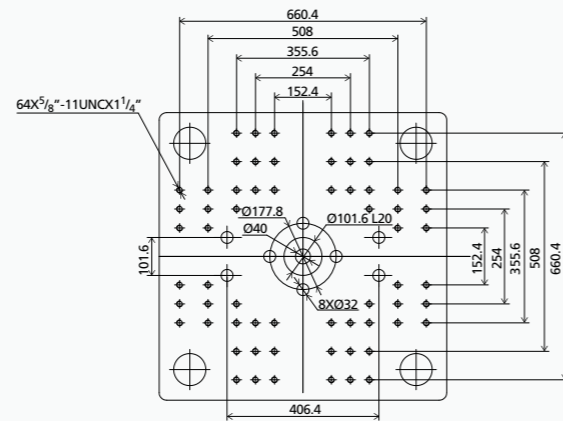

AMERICAN VERSION FIXED PLATEN

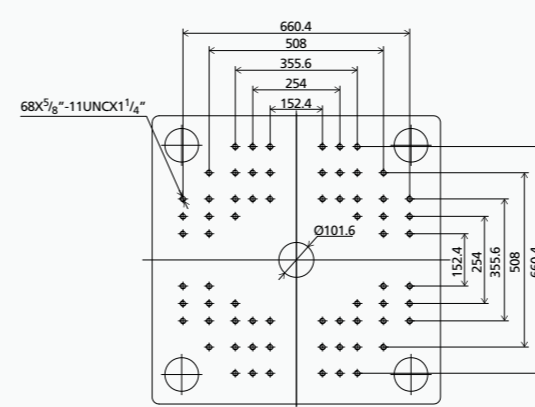

MOVABLE PLATEN

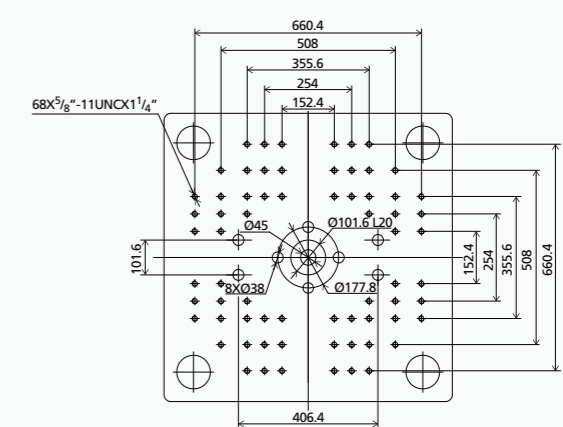

JAPANESE VERSION FIXED PLATEN

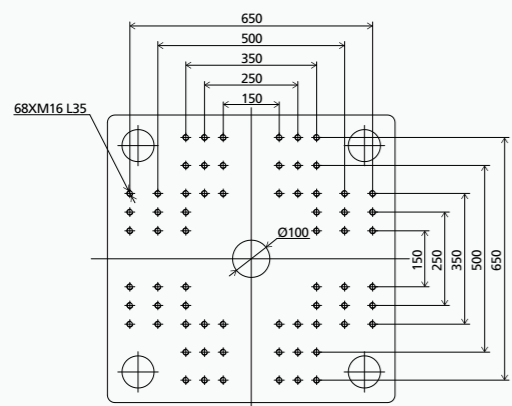

MOVABLE PLATEN

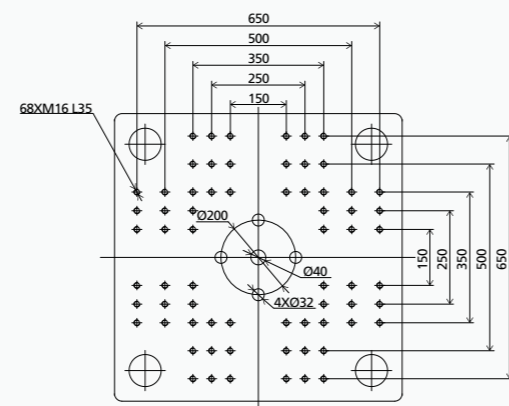

JAPANESE VERSION FIXED PLATEN

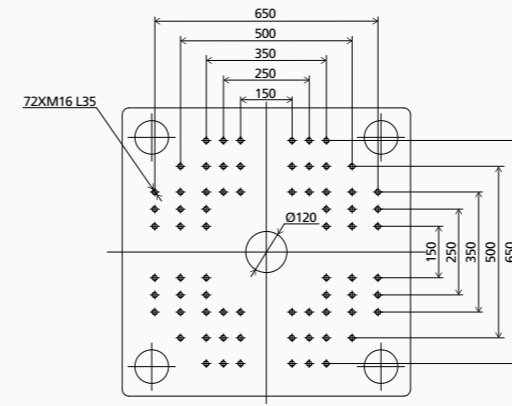

MOVABLE PLATEN

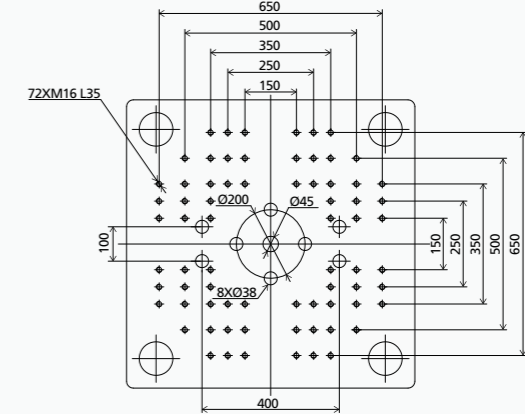

We reserve the right to make changes as a result of further technical advances.

PLATEN LAYOUT ZE2300 III

EUROPEAN VERSION FIXED PLATEN

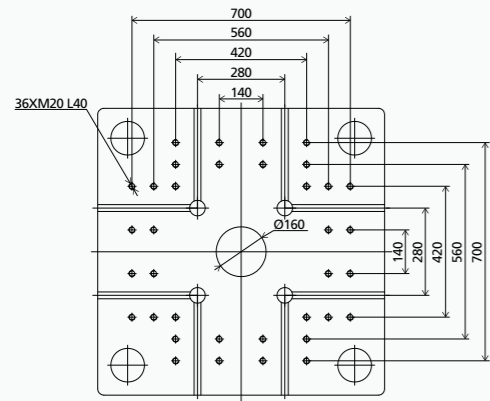

MOVABLE PLATEN

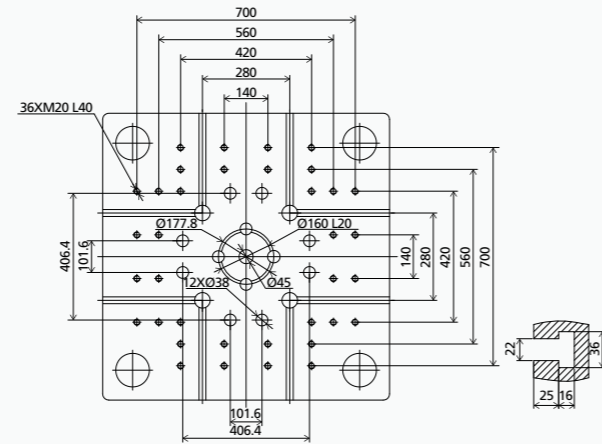

EUROPEAN VERSION FIXED PLATEN

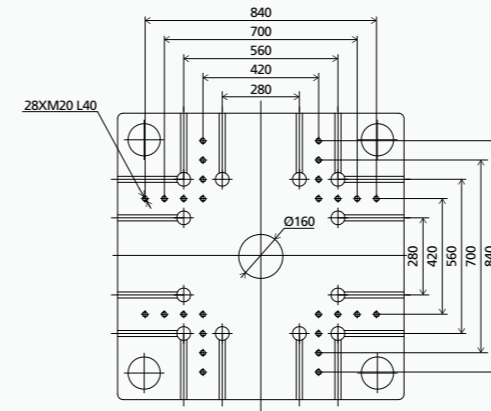

MOVABLE PLATEN

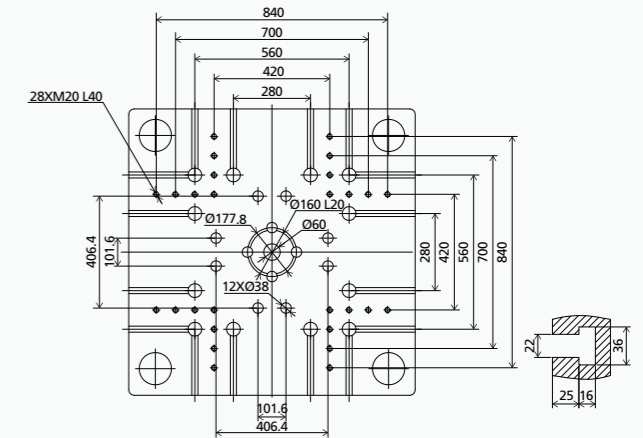

AMERICAN VERSION FIXED PLATEN

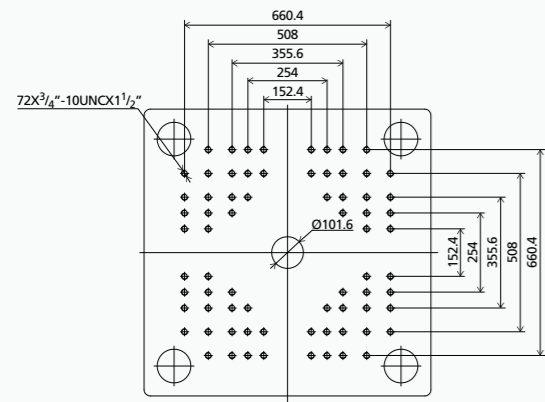

MOVABLE PLATEN

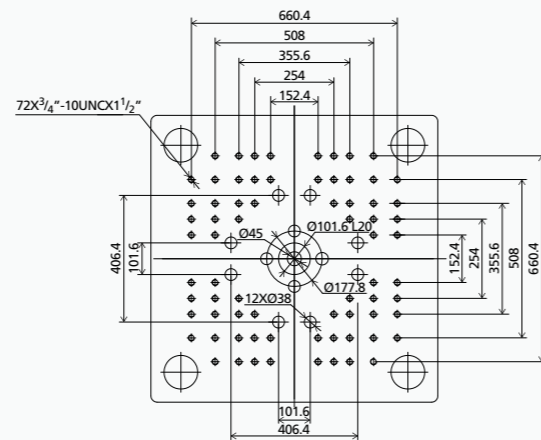

AMERICAN VERSION FIXED PLATEN

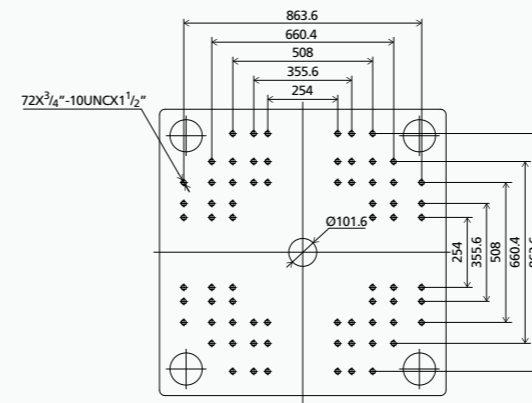

MOVABLE PLATEN

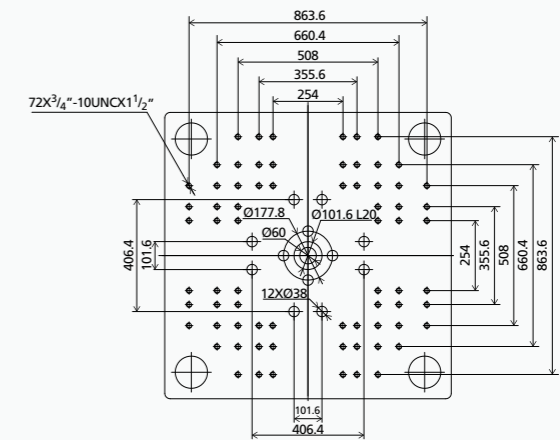

JAPANESE VERSION FIXED PLATEN

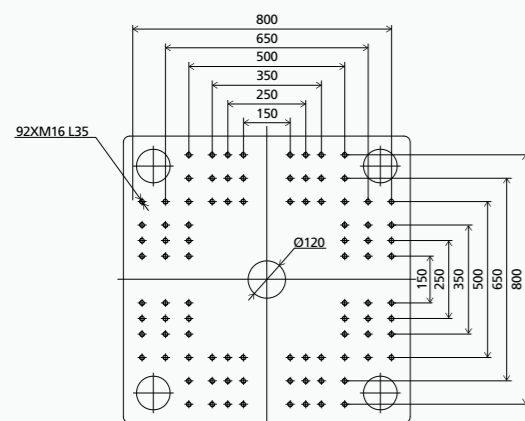

MOVABLE PLATEN

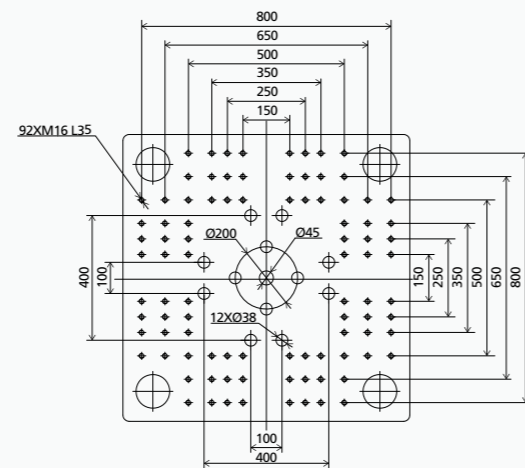

JAPANESE VERSION FIXED PLATEN

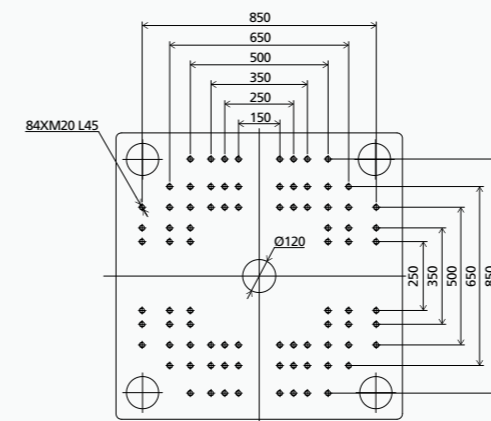

MOVABLE PLATEN

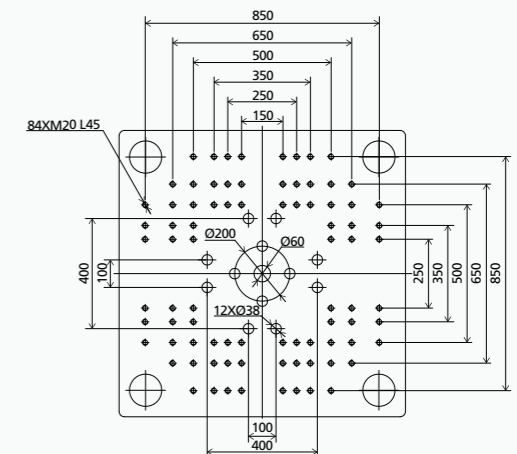

We reserve the right to make changes as a result of further technical advances.

PLATEN LAYOUT ZE3600 III

EUROPEAN VERSION FIXED PLATEN

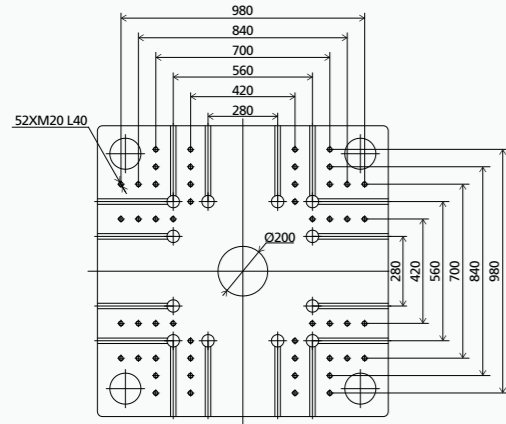

MOVABLE PLATEN

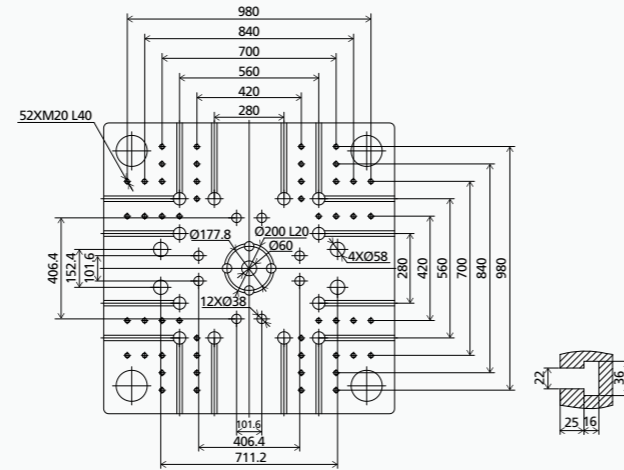

AMERICAN VERSION FIXED PLATEN

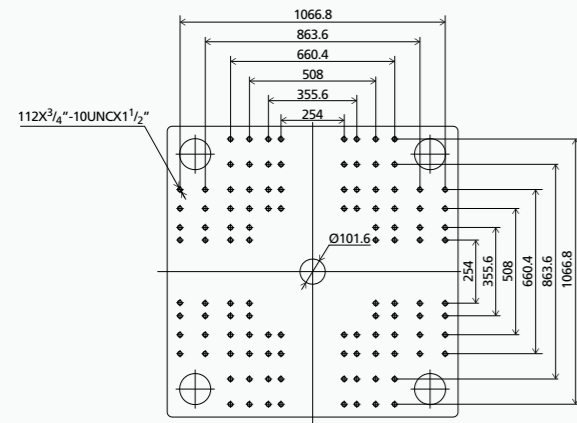

MOVABLE PLATEN

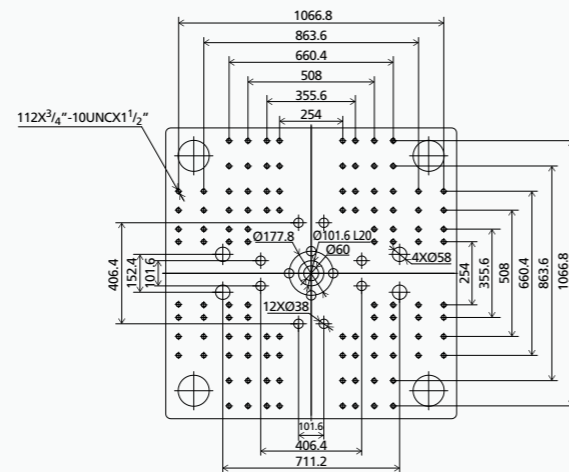

JAPANESE VERSION FIXED PLATEN

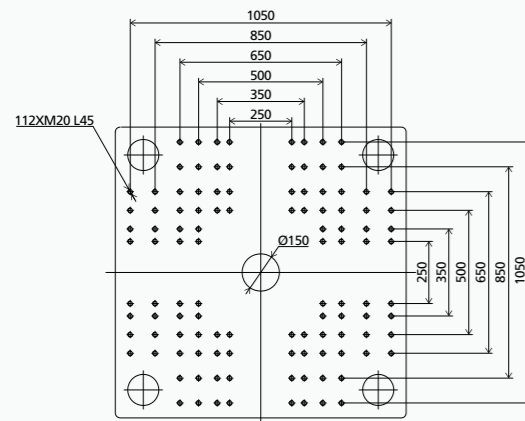

MOVABLE PLATEN

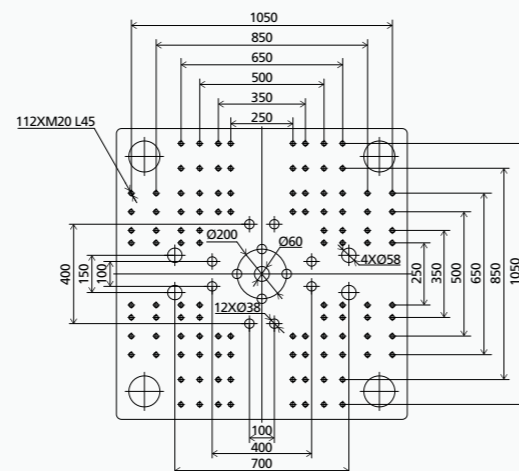

We reserve the right to make changes as a result of further technical advances.

STANDARD EQUIPMENT LIST

GENERAL EQUIPMENT

- » Basic safety device according to GB/22530-2010.
- » ZHAFIR colors: RAL9010, RAL5003
- » Power supply: 380VAC, 3PH+N+PE
- » Sigmatek controller, 15.1 inch touch screen
- » Injection, dosing and platen movement driven independently by servo motor, optical encoder position detection.
- » LUBE central lubrication system
- » Integrated servo hydraulic pack for ejection and carriage movement.

INJECTION UNIT

- » Abrasion-resistant screw set, general version
- » Open nozzle
- » Barrel heating temperature PID control, SSR
- » Extended nozzle, temperature PID control independently
- » Feeding zone temperature closed-loop control
- » Injection speed 6 steps
- » Speed responding mode adjustable
- » Holding pressure 4 steps
- » Pressure responding mode adjustable
- » V/P switch over methods by position/ time/ pressure combinations
- » Dosing rotation speed 3 steps
- » Back pressure 3 steps
- » HPM over-filling protection function
- » Screw retraction before and/or after dosing
- » Auto purge
- » Nozzle sealing force programmable control
- » Swiveling injection unit

CLAMPING UNIT

- » 5-point twin toggle mechanism
- » Center pressing platen
- » Clamping force settable at control panel
- » Automatic mold-height adjustment
- » Platen moving speed 6 steps
- » AI mold protection
- » Clamping force pre-release
- » Ejector speed 3 steps
- » Ejector pressure 3 steps
- » Multi ejection function
- » Ejection parallel to mold opening

FUNCTIONS & CONTROLS

- » Multi-language available (Chinese, German, English, Japanese etc.)
- » Metric/Imperial unit selectable
- » Dosing parallel to mold opening
- » Injection compression
- » Production assistant device function
- » Maintenance alert
- » 5000 cycles process data recording
- » Amendment report
- » Alarm record
- » Quality control function
- » Mold profile data memory (up to 200 sets)
- » 3 USB interface
- » USB printer interface
- » Injection speed & pressure curve
- » 1 free programmable I/O
- » Mold ejector protection interface
- » EUROMAP 12 interface for handling device
- » Auxiliary socket 3PH/380V 32A×1, 16A×2
- » 3 color alarm lamp (red/yellow/green)

OTHERS

- » Tool kit & spare parts package
- » Leveling pads
- » Documents with machine
- » Operating manual

